

Dual

C 846

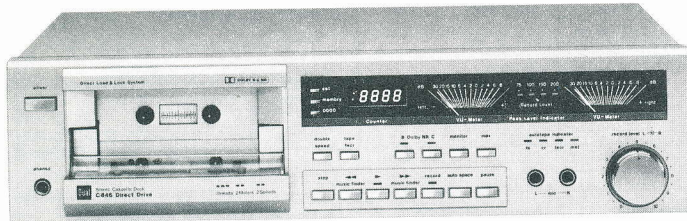

Service-Anleitung Service Manual Instructions de Service

Technische Daten (typische Werte)	Technical Data (typical values)	Caractéristiques techniques (valeurs caractéristiques)				
			Dolby B	Dolby C	Dolby B	Dolby C
Das Gerät erfüllt bzw. übertrifft die in DIN 45 500 festgelegten Anforderungen an Geräte der Heimstudio-Technik (HiFi).	The unit meets the requirements of DIN 45 500 for domestic HiFi equipment. The data given are based on the current DIN reference tapes.	Cet appareil surpasse par ses performances les exigences de la norme DIN 45 500 (matériel HiFi, grand public).				
Bandgeschwindigkeit	Tape speed	Vitesse de la bande	9,5 cm/s		4,75 cm/s	
Kurzzeitige Geschwindigkeitsschwankungen (Tonhöhenchwankungen) W.R.M.S. nach DIN Aufnahme/Wiedergabe	Wow and flutter Weighted RMS to DIN for recording/playback	Fluctuations instantanées de la vitesse (variations de la hauteur du son) W.R.M.S. selon DIN enregistrement/lecture	0,03 % 0,07 %		0,045 % 0,12 %	
Übertragungsbereich (bezogen auf DIN-Toleranzfeld) Fe-Band CrO ₂ -Band FeCr-Band Reineisen-Band	Frequency response (ref. to DIN tolerances) Standard Fe tape CrO ₂ tape FeCr tape Metal tape	Bande passante (ramenée à la plage de tolérance DIN) Bande Fe Bande CrO ₂ Bande FeCr Bande fer pur	25 - 24 000 Hz 25 - 24 000 Hz 25 - 24 000 Hz 25 - 24 000 Hz		25 - 16 000 Hz 25 - 17 000 Hz 25 - 18 000 Hz 25 - 19 000 Hz	
Ruhegeräuschspannungsabstand mit Dolby NR Fe-Band CrO ₂ -Band FeCr-Band Reineisen-Band	Signal-to-noise ratio with Dolby NR Standard Fe tape CrO ₂ tape FeCr tape Metal tape	Rapport signal/bruit avec Dolby NR Bande Fe Bande CrO ₂ Bande FeCr Bande fer pur	67 67 69 69	74 74 76 76	65 65 67 67	72 72 74 74
Übersprechdämpfung (bei 1000 Hz) zwischen zusammengehörigen Kanälen zwischen Kanälen in Gegenrichtung	Channel separation (at 1,000 Hz) between stereo channels in opposite direction	Diaphonie (à 1000 Hz) en sens stéréo en sens inverse	40 dB 70 dB			
Löschdämpfung (bei 1000 Hz)	Erase (at 1000 Hz)	Atténuation d'effacement (à 1000 Hz)	70 dB			
Oszillator-Frequenz (Gegentaktoszillator)	Oscillator (push/pull oscillator)	Fréquence de l'oscillateur (oscillateur push-pull)	105 kHz			
Eingänge (Empfindlichkeit für 0 dB) Mikrofon (1/4" Koax.-Buchse) Receiver/Verstärker (RCA-Buchsen)	Inputs (sensitivity at 0 dB) Microphone (1/4" coaxial jack) Receiver/amplifier (RCA jacks)	Entrées (sensibilité pour 0 dB) Micro (prise coaxiale de 1/4") Ampli-tuner/amplificateur (prises RCA)	0,4 mV / 10 kΩ 70 mV / 60 kΩ			
Ausgänge Receiver/Verstärker (RCA-Buchsen) Kopfhörer (1/4" Koax.-Buchse)	Outputs Receiver/amplifier (RCA jacks) Headphones (1/4" coaxial jack)	Sorties Ampli-tuner/amplificateur (prises RCA) Casque d'écoute (prise coaxiale de 1/4")	560 mV / 4 kΩ 4 - 2000 Ω			
Umspulzeit für C 60 Cassette	Fast winding time for C 60 cassettes	Temps de rebobinage pour cassette C 60	80 s			
Bandlaufüberwachung (elektronisch) Abschaltzeit	Tape monitor (electronic) shut-off time	Contrôle du défilement de bande (électronique) Temps de déclenchement	1,5 s			
Netzspannung	Line voltage	Tension secteur	Model Europe 230 V Model USA/Kanada 115 V			
Netzfrequenz	Line frequency	Fréquence secteur	50/60 Hz			
Leistungsaufnahme	Power requirement	Consommation	40 W			

Abgleichanleitung C 846 · Adjustment instructions C 846

Signalquelle Signal source	Einstellung Signalquelle Signal source adjustment	Einstellung Gerät Unit adjustment	Meßgerät-Anschluß Testgear connection	Abgleichposition Adjustment position	Abgleich, Bemerkung Adjustment, Remarks
Bandlauf, Bandzug · Tape Run, Tape Tension (4,75 cm/s)					
Spiegelkassette Mirror cassette		Play: ON			Bandlauf prüfen Check tape run
Bandzugmeßkassette Torque Meter cassette				VR 601	50 ± 5 p/cm
Bandgeschwindigkeit · Tape Speed					
Meßkassette 1 Test cassette 1	3150 Hz	Play: ON Double Speed: OFF	Frequenzzähler an Frequency counter to OUTPUT L/R	VR 701	3150 Hz, \pm 4,75 cm/s
		Double Speed: ON		VR 702	6300 Hz, \pm 9,5 cm/s
Azimut · Azimuth (4,75 cm/s)					
Meßkassette 21 Test cassette 21	10 kHz	Play: ON	NF-Voltmeter an AF-voltmeter to OUTPUT L/R	Azimuthschraube A Azimuth screw A	Maximum, mit Lack sichern Lock with Lacquer
Wiedergabepegel · Playback level (4,75 cm/s)					
Meßkassette 21 Test cassette 21	400 Hz Dolby	Play: ON Dolby B: ON	NF-Voltmeter an AF-voltmeter to OUTPUT L/R	VR 102 L CH VR 102' R CH	560 mV
Wiedergabefrequenzgang · Frequency response (4,75 cm/s)					
Meßkassette 21 Test cassette 21	400 Hz/10 kHz (-20 db)	Play: ON	NF-Voltmeter an AF-voltmeter to OUTPUT L/R	VR 101 L CH VR 101' R CH	10-kHz-Pegel auf 400-Hz-Pegel angleichen. Adjust to level symmetry
Oszillator, HF-Sperrkreis · Oscillator, RF-trap (4,75 cm/s)					
IEC IV-Kassette IEC IV-cassette		Tape: Met Record: ON	Frequenzzähler an Frequency counter to TP 2 (R 362)	OSC 1	105 kHz \pm 2 kHz
			NF-Voltmeter an AF-voltmeter to TP 5 (R 164) TP 6 (R 164')	T 101 L CH T 101' R CH	Minimum HF Minimum RF
Aufnahmepegel · Record Level (4,75 cm/s)					
NF-Generator an AF-generator to INPUT L/R	400 Hz ca. 100 mV TDK MA AC-712 IEC IV	Tape: Met Record: ON	NF-Voltmeter an AF-voltmeter to OUTPUT L/R	Record Level	560 mV OUTPUT L/R
				VR 104 L CH VR 104' R CH	560 mV
HF-Vormagnetisierung · RF-Magnetic-Biasing (4,75 cm/s)					
NF-Generator an AF-generator to INPUT L/R	400 Hz, 12 kHz ca. 100 mV TDK MA AC-712	Record: ON Monitor: ON Tape: Met	NF-Voltmeter an AF-voltmeter to OUTPUT L/R	Record Level	56 mV OUTPUT L/R
		BASF IEC I Tape: Fe		VR 105 L CH VR 105' R CH	Bei Wiedergabe wird der 12-kHz-Pegel dem 400-Hz-Pegel angeglichen. Mehr Höhen = gegen den Uhrzeigersinn drehen. Adjust to level symmetry on playback test frequency, at treble emphasis: turn counter clockwise
		BASF IEC II Tape: Cr		VR 301	
		Sony Duad IEC III Tape: FeCr		VR 303 VR 302	
Pegelanzeige · Level indicator (4,75 cm/s)					
NF-Generator an AF-generator to INPUT L/R	400 Hz ca. 100 mV IEC IV Cassette	Tape: Met Dolby B: ON Record: ON Monitor: OFF	NF-Voltmeter an AF-voltmeter to OUTPUT L/R	Record Level	560 mV OUTPUT L/R
				VR 201 L CH VR 201' R CH	VU-Meter +3 db
				Record Level	630 mV OUTPUT L/R
				VR 304	LED Indicator 150%
Meßkassette 1: Gleichlaufkassette 3150 Hz Meßkassette 21: 400 Hz Dolby-Pegel, 200 nWb/m 400 Hz - 20 dB, 10 kHz - 20 dB		Test cassette 1: Tape speed test cassette 3150 Hz Test cassette 21: 400 Hz Dolby-level 200 nWb/m 400 Hz - 20 dB, 10 kHz - 20 dB			

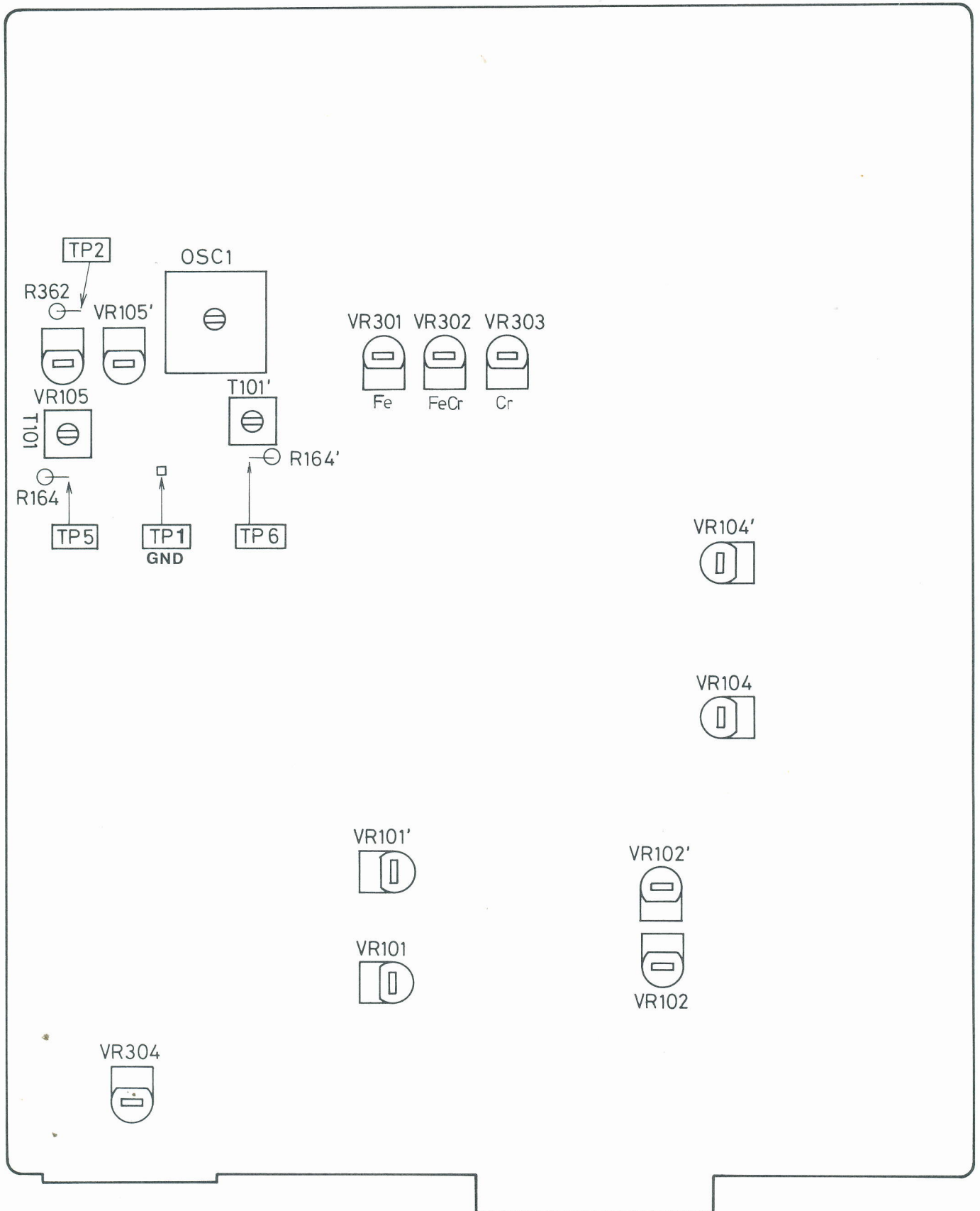

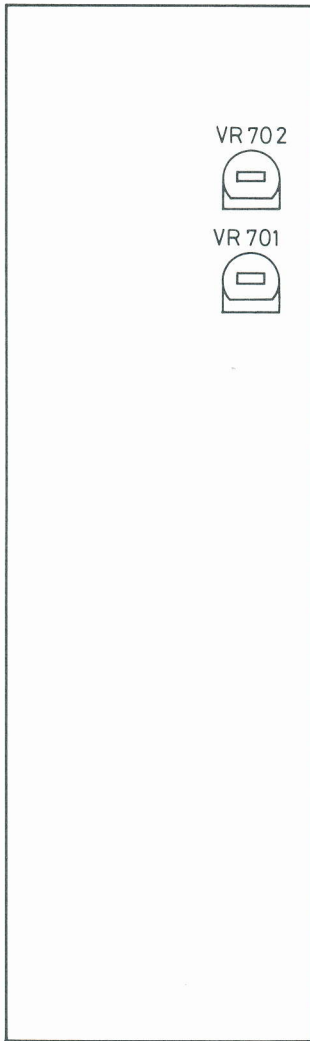

Controllplatte/Control board/Plaque de controle

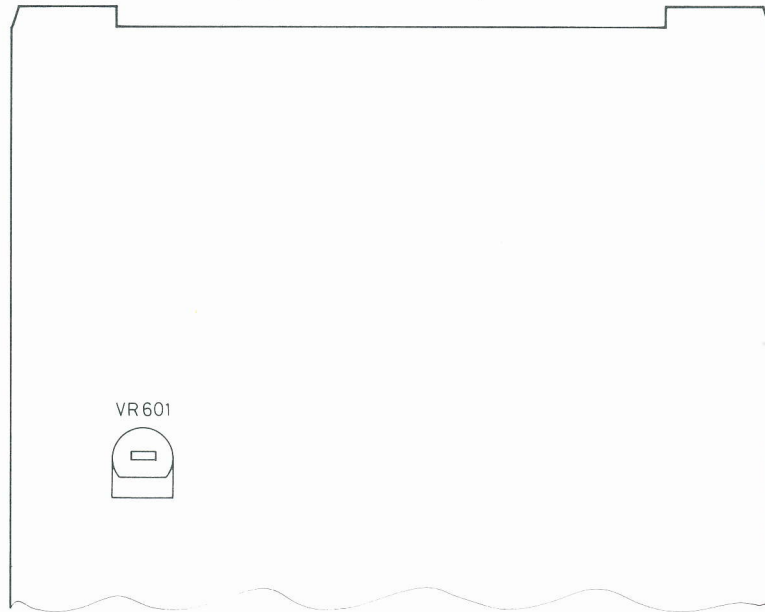

Anschlußplatte/Connection plate/Plaque de branchement

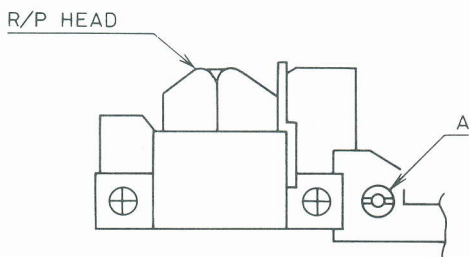
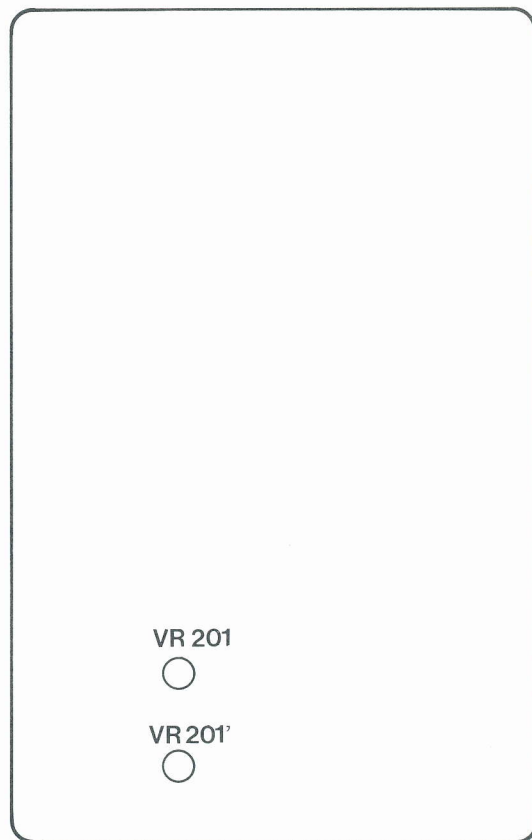

METER LAMP PCB

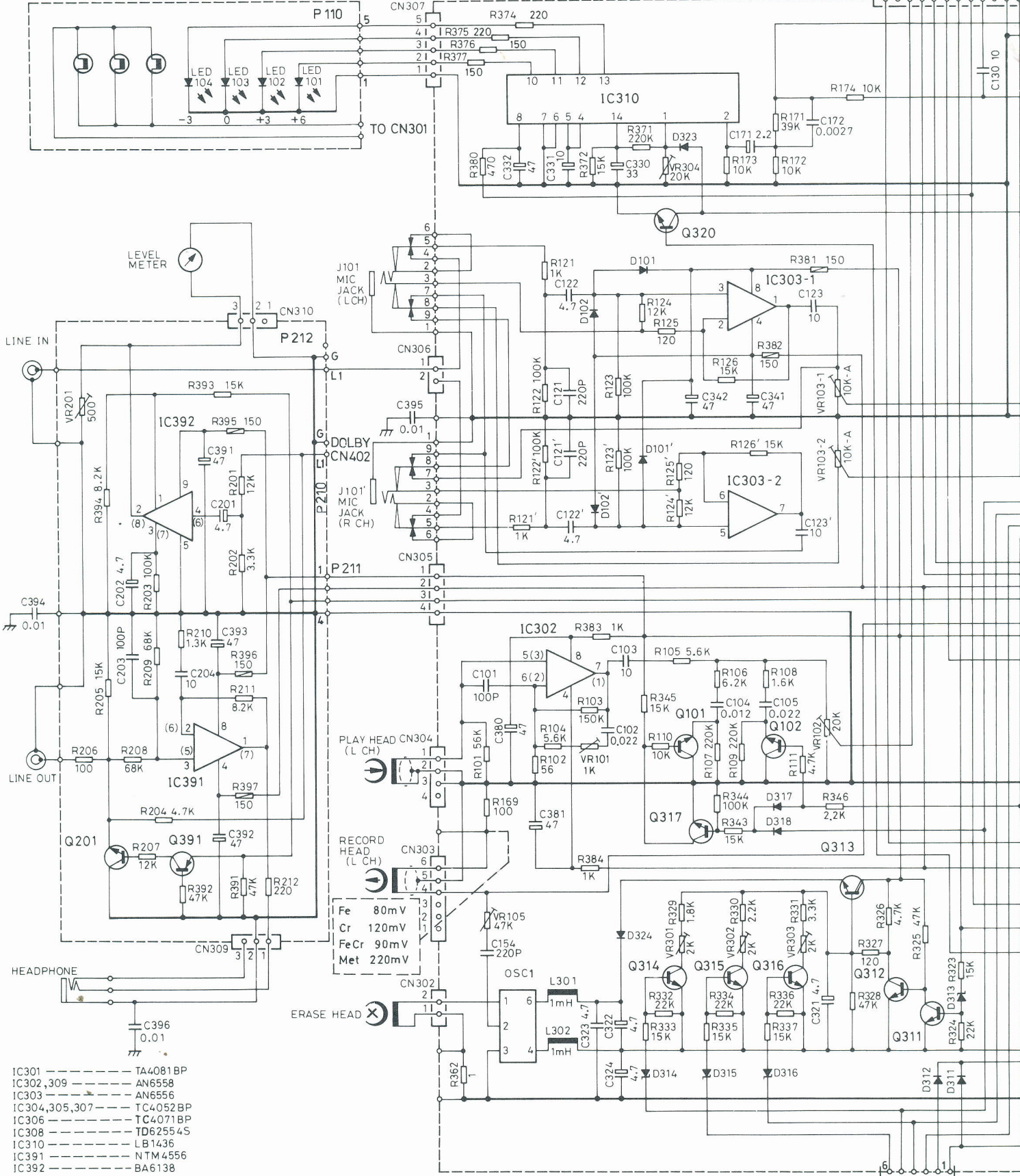
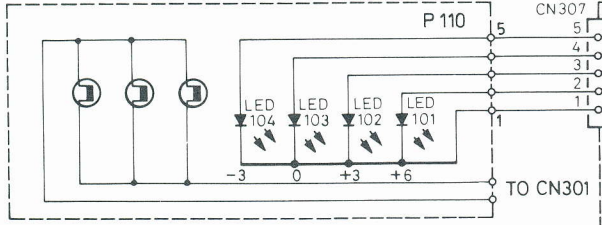

- IC301 ----- TA4081BP
- IC302,309 ----- AN6558
- IC303 ----- AN6556
- IC304,305,307 ----- TC4052BP
- IC306 ----- TC4071BP
- IC308 ----- TD62554S
- IC310 ----- LB1436
- IC391 ----- NTM4556
- IC392 ----- BA6138

- Q101,102,104,105,101',102',104',105',304,305,312,314~317,319 ----- 2SC1685-S
- Q103,103',201 ----- 2SD1302-T
- Q301,308 ----- 2SD1406-GR
- Q302, Q309 ----- 2SB1015-GR
- Q303,307,310,318,391 ----- 2SA564-S
- Q306,311 ----- 2SC3112-B
- Q313 ----- 2SD1198-R
- Q320 ----- UN4211

- D101,102,101',102',303,306,308,309,311,312,317~319,323,324 ----- MA150
- D301 ----- 2W02
- D302 ----- W02
- D304 ----- SR1K-2
- D305 ----- HZ12C-1L
- D307,325 ----- OA90-AM
- D310 ----- HZ9C-1L
- D313~316 ----- HZ15-1
- D321,322 ----- HZ6B-3

FeCr
Fe
Cu
ML
4.76
9.5
CN309
SELECT BOARD
P 711

CONTROL BOARD
CN 606

SELECT BOARD

MAIN BOARD
CN 309

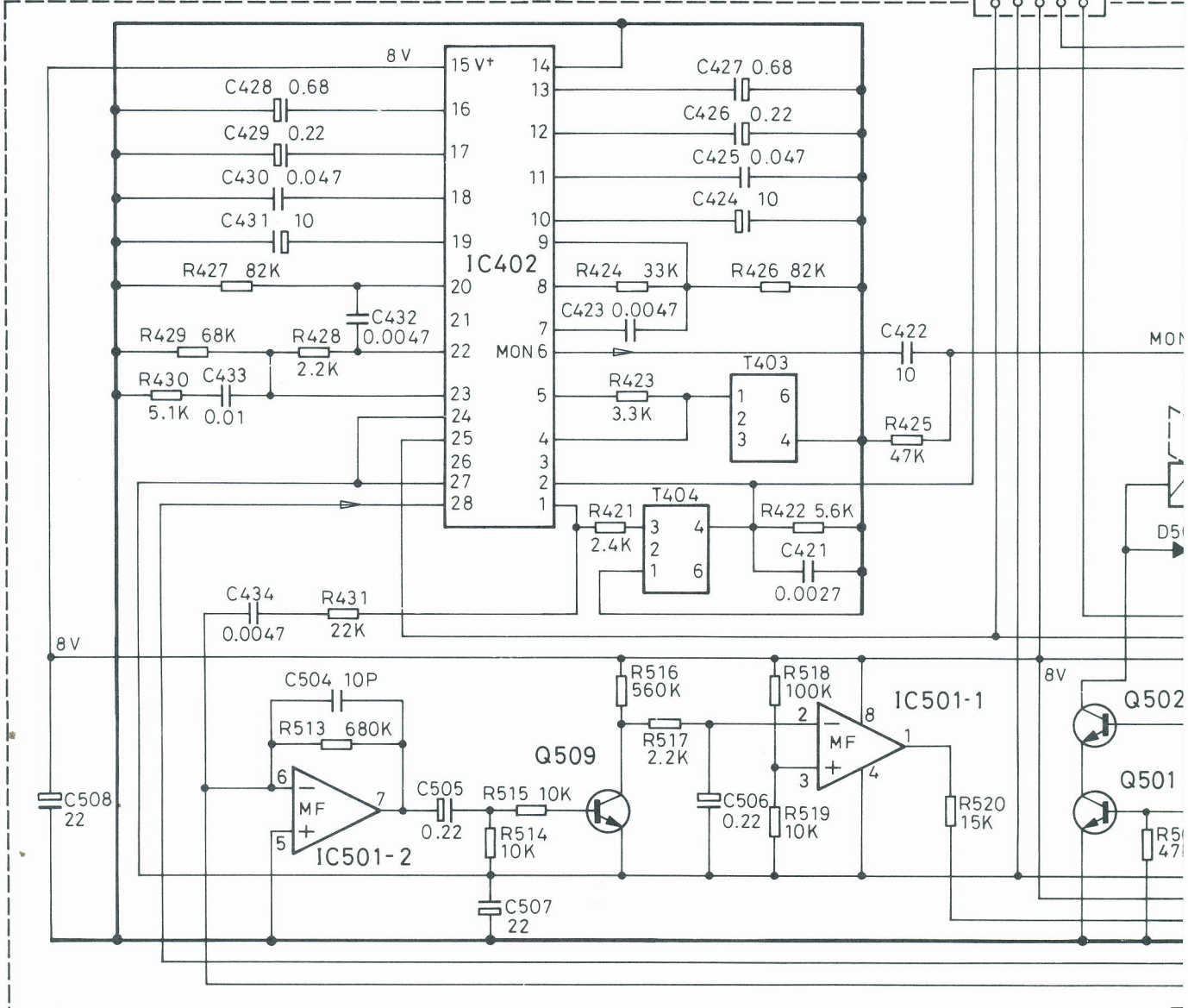
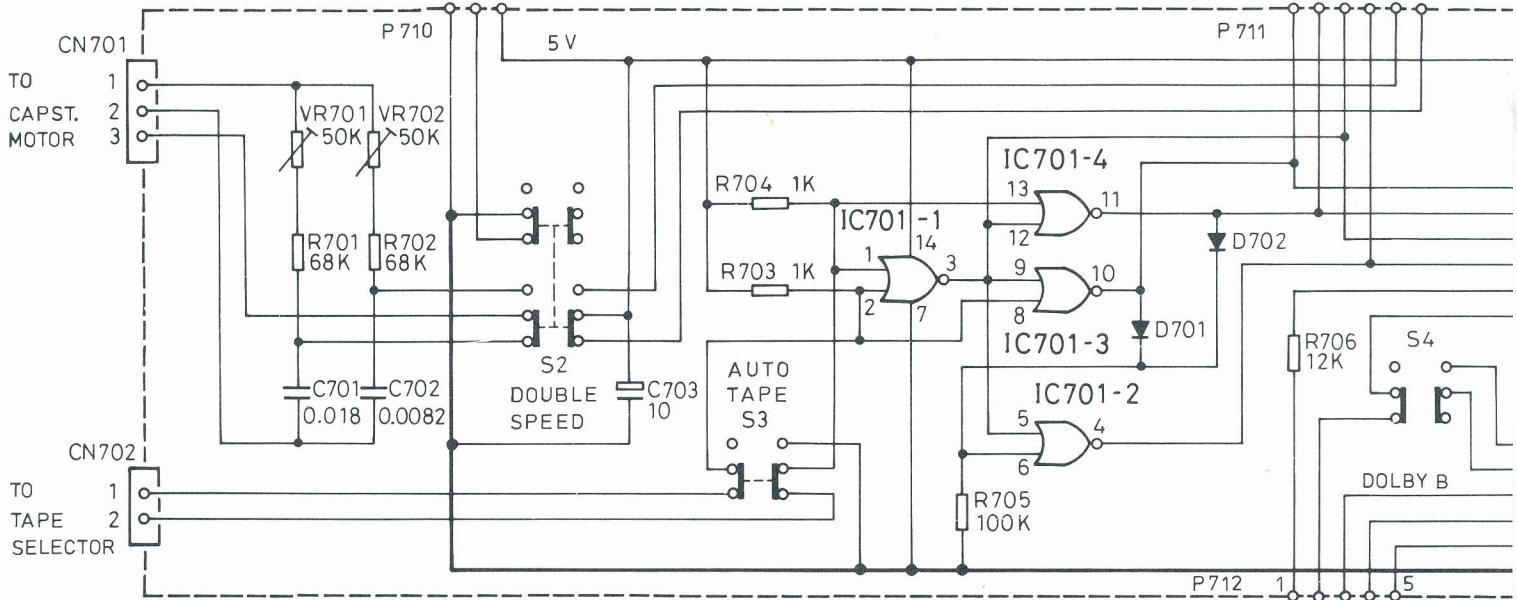

- | | | |
|-----------------------|------------------------|---|
| IC401,402 ----TEA0665 | Q501,503 ----2SC3112-B | S2 --- DOUBLE SPEED SWITCH (4.76 cm/sec POSITION) CN403 |
| IC501 ---- AN6556 | Q504 ---- 2SA564-S | S3 --- AUTO TAPE SWITCH (AUTO POSITION) |
| IC701 ---- TC4001BP | D501,701,702 --- MA150 | S4 --- DOLBY NR B SWITCH (OFF POSITION) |
| IC702 ---- TD62554S | LD4~7 ---- GL-9NG24 | S5 --- DOLBY NR C SWITCH (OFF POSITION) |
| Q401,402,502, | LD8,9 ---- GL-9HY24 | S6 --- MONITOR SWITCH (OFF POSITION) |
| 509 ---- 2SC1685-S | | S7 --- MPX FILTER SWITCH (OFF POSITION) |

MUSIC FINDER

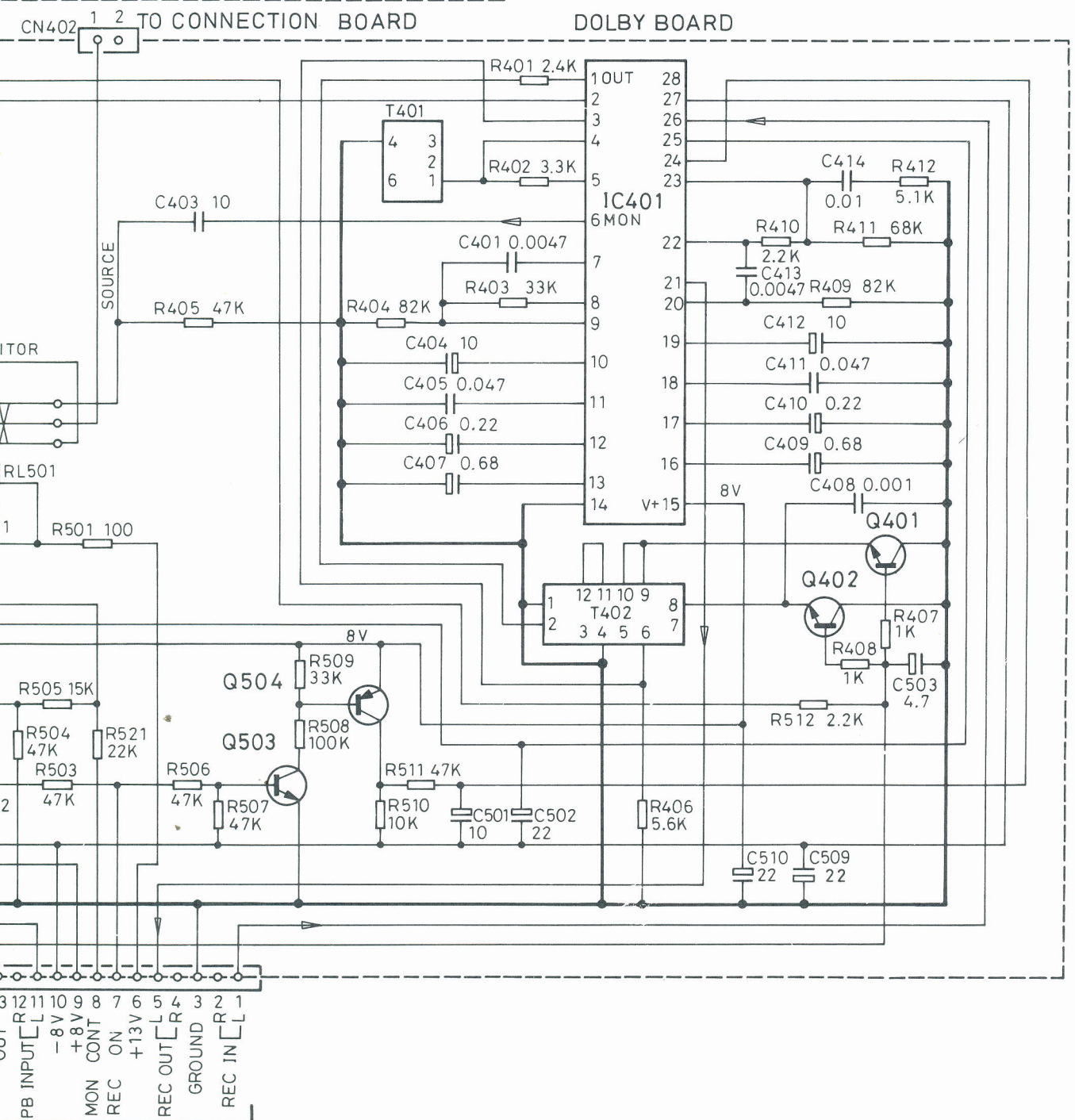
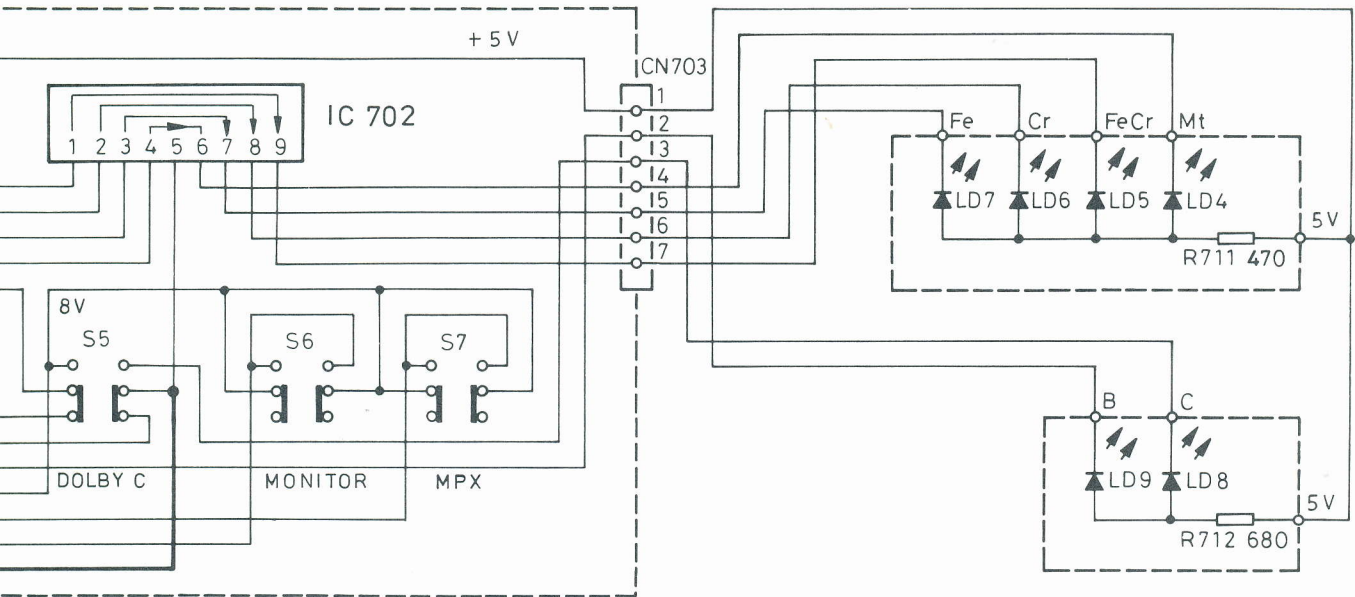

0 MAIN BOARD
CN 308

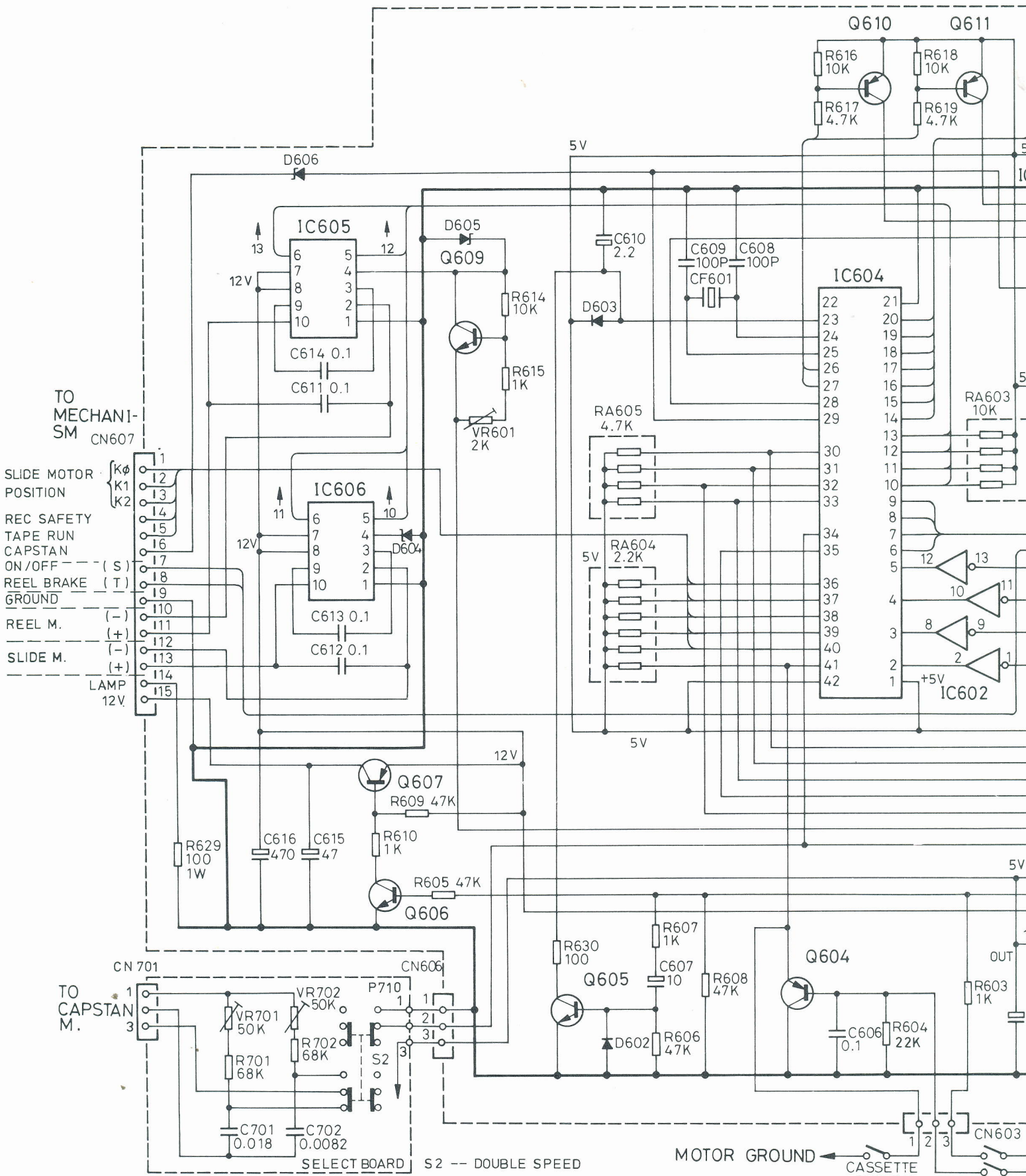

- IC601 ---- M54560P
- IC602 ---- TC4049UBP
- IC603 ---- TD62104P
- IC604 ---- TMP4321
- IC605 ---- BA6109
- IC606 ---- BA6209
- IC607 ---- AN7805

- Q601 ---- 2SK246-Y1
- Q602 ---- 2SC1685-Q
- Q603 ---- 2SC1406-O
- Q604,610,611-2SA564-S
- Q605,606 ---- 2SC3112-B
- Q607 ---- 2SB1015-GR
- Q608,609 ---- 2SC1685-S

- D601 ---- HZ12-C1
- D602 603,607, 801,802 ---- MA150
- D604 ---- HZ9C-1
- D605 ---- HZ7B-1
- D606 ---- HZ3B-2

- LD1 ---- SL1
- LD2 ---- GL-
- LD3 ---- GL-

CONTROL BOARD

DISPLAY COUNTER

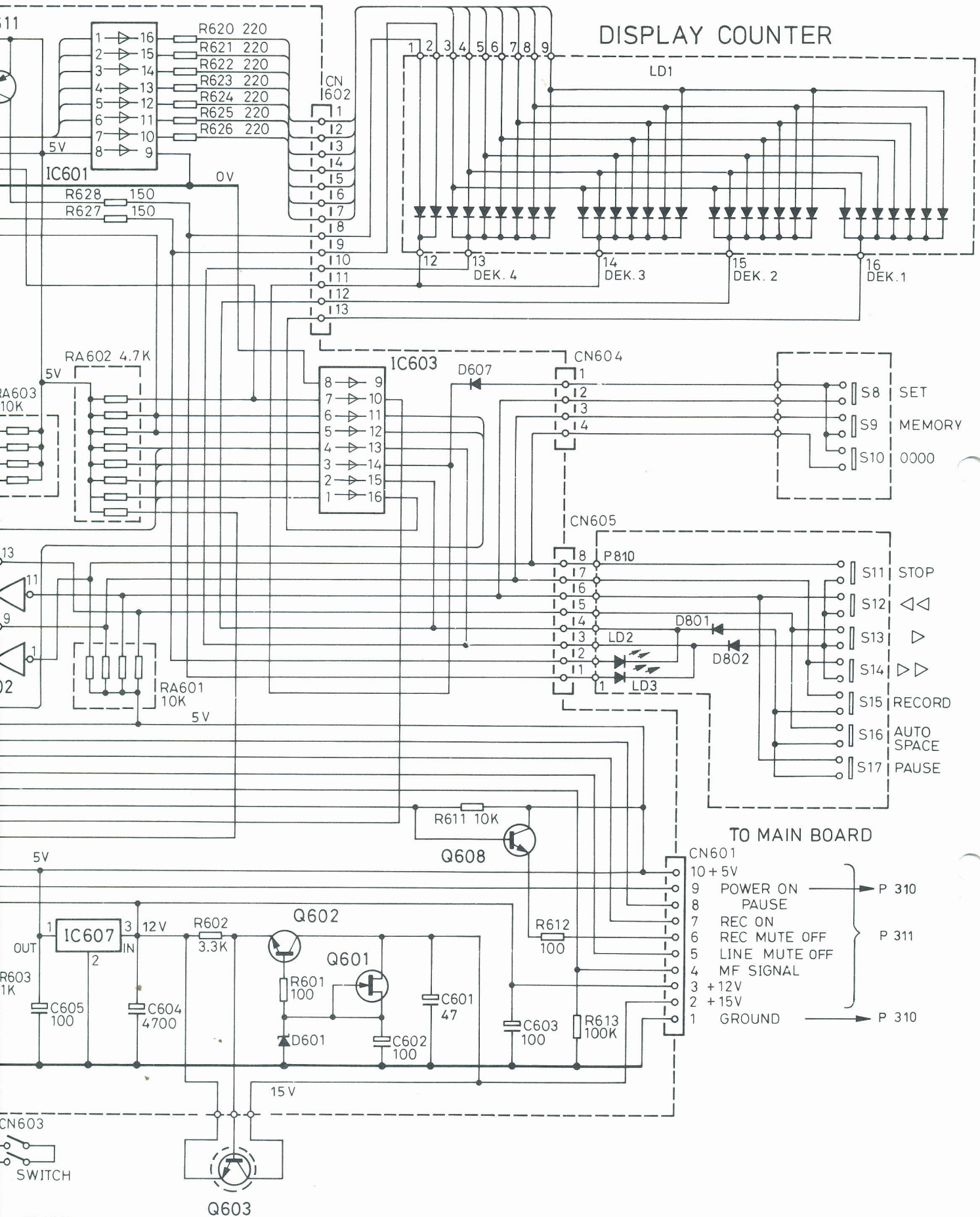

--SL1012
 --GL-9NG24
 --GL-9PR24

EQUALIZER BOARD

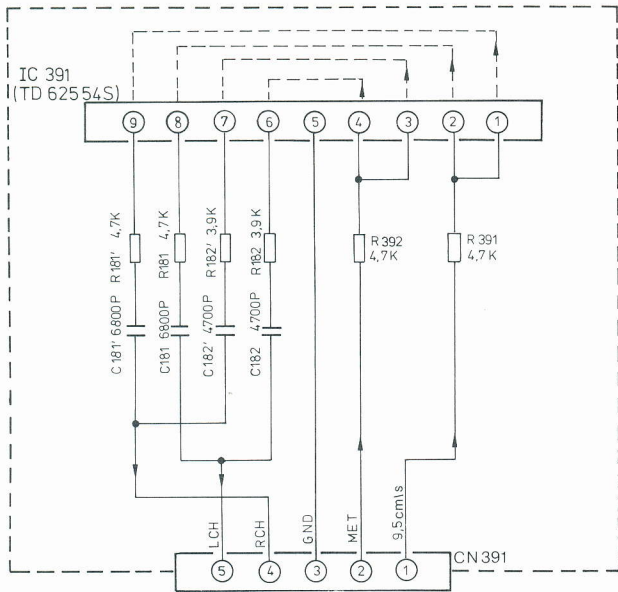

P 312
TO MAIN BOARD

Legende IC 304, IC 305

IC 304 activ: Low to Pin 6 (INH) \triangleq 9,5 cm/s
IC 305 activ: Low to Pin 6 (INH) \triangleq 4,75 cm/s

Pin	B 9	A 10	Y 3
Fe	H	L	2
Cr	H	H	4
FeCr	L	L	1
Met	L	H	5

Legende IC 307

	Pin	B 9	A 10	X 13
4,75 cm/s	Fe	H	L	15
	Cr	H	L	15
	FeCr	L	L	12
	Met	L	L	12
9,5 cm/s	Fe	H	H	11
	Cr	H	H	11
	FeCr	L	H	14
	Met	L	H	14

Legende IC 308

Pin	4	2
Fe	H	H
Cr	H	H
FeCr	L	L
Met	L	L



2SA 564
2SC 1685
2SC 3112
2SD 1302



2SK 246



UN 4211



2SD 1198



2SB 1015
2SD 1405
2SD 1406



AN 7805

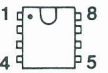

AN 6556
AN 6558
NTM 4556

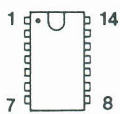

TC 4001
TC 4071
TC 4081
TC 1436

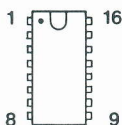

TC 4052
TC 4069
TD 62104
LB 1436

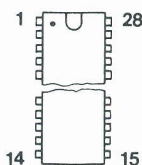

TEA 0665

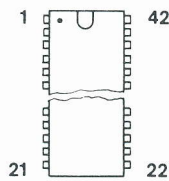

TMP 4321

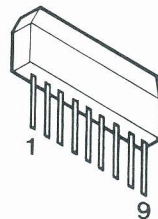

TD 62554

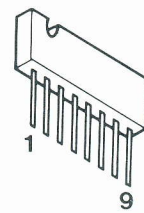

BA 5138

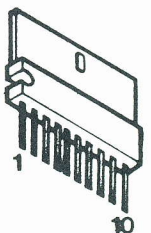

BA 6109
BA 6209

Verbindungen/Connections

Grundplatte/Main Board

- CN 301 → Lamp VU-Meter
- CN 302 → Eresize, Head
- CN 303 → Record Head
- CN 304 → Play Head
- CN 305 → P 211 Connection Board
- CN 306 → P 212 Connection Board
- CN 307 → P 110 Peak Level Board
- CN 308 → CN 403 Dolby Board
- CN 309 → P 711 Selection Board
- P 310 → CN 601 Control Board
- P 311 → CN 601 Control Board
- P 312 → CN 391 Equalizer Board

Controllplatte/Control Board

- CN 601 → P 310, P 311 Main Board
- CN 602 → Counter Board
- CN 603 → DLL, Cassette Switch
- CN 604 → Memory Switch
- CN 605 → P 810 Touch Switch Board
- CN 606 → P 710 Selection Board
- CN 607 → Laufwerk

Anschlußplatte/Connection Board

- CN 309 → Headphone
- CN 310 → VU-Meter
- P 210 → CN 402 Dolby Board
- P 211 → CN 305 Main Board
- P 212 → CN 306 Main Board

Dolbyplatte/Dolby Board

- CN 401 → P 712 Selection Board
- CN 402 → P 210 Connection Board
- CN 403 → CN 308 Main Board

Selectionplatte/Selection Board

- CN 701 → Capstan Motor
- CN 702 → Tape Selector (Laufwerk)
- CN 703 → Autotape Indicator
- P 710 → CN 606 Control Board
- P 711 → CN 309 Main Board
- P 712 → CN 401 Dolby Board

Tiptastenplatte/Touch Switch Board

- P 810 → CN 605 Control Board

Entzerrerplatte/Equalizer Board

- CN 391 → P 312 Main Board

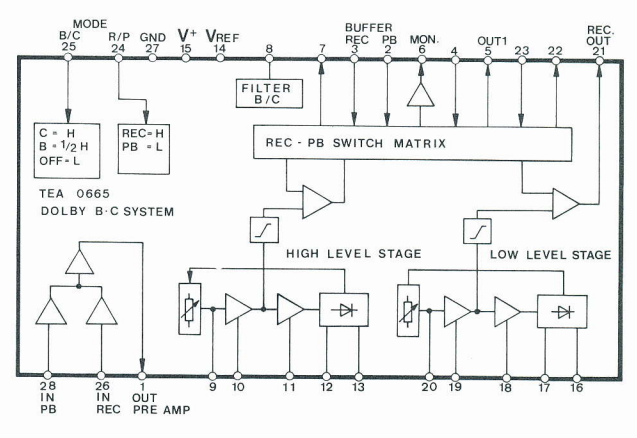
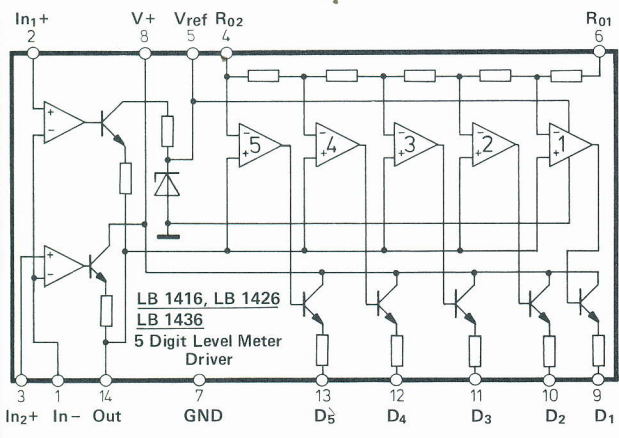
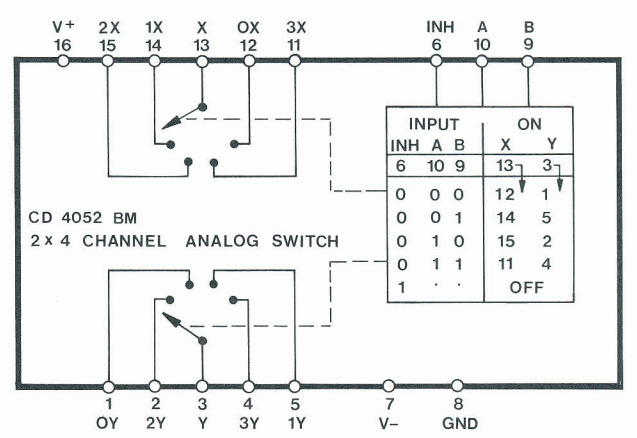
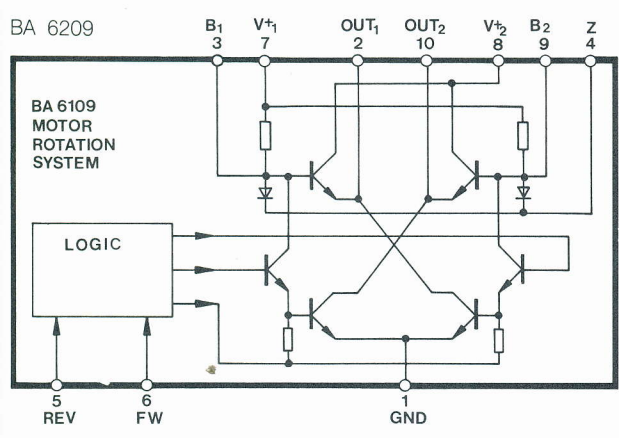
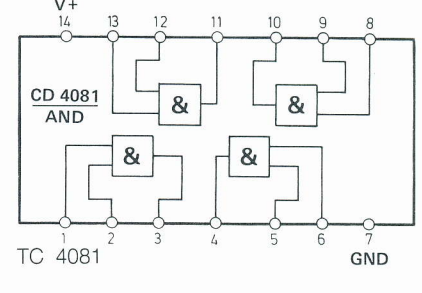
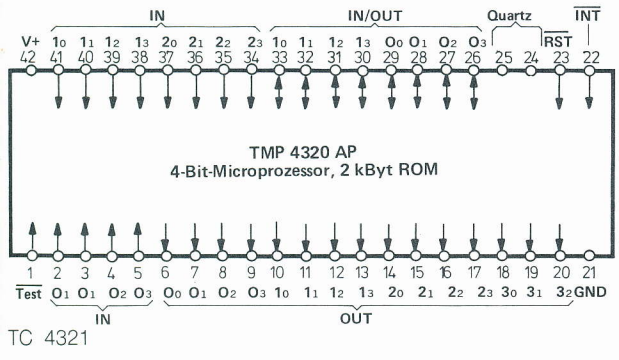
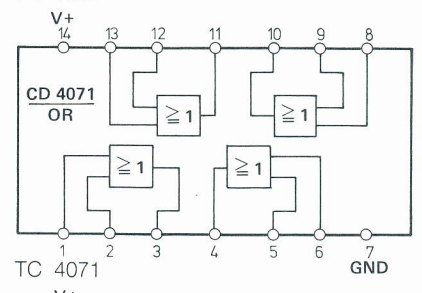
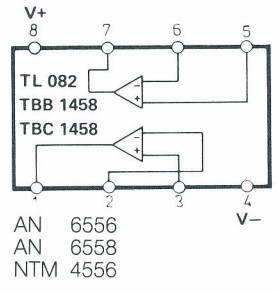
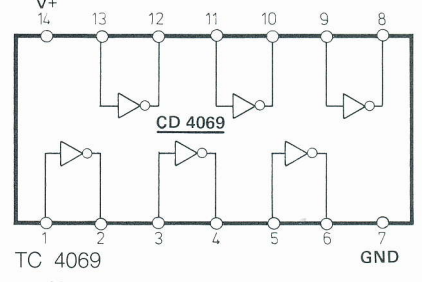
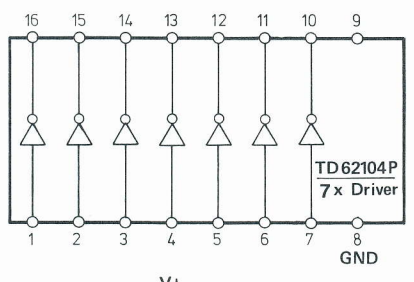
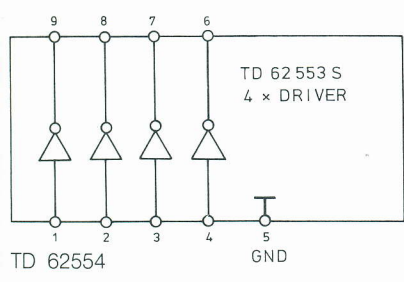
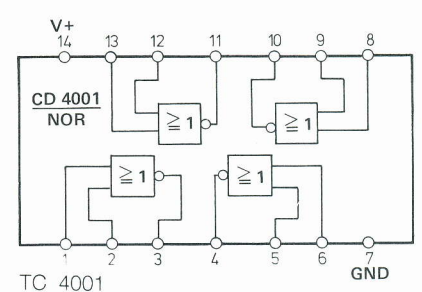
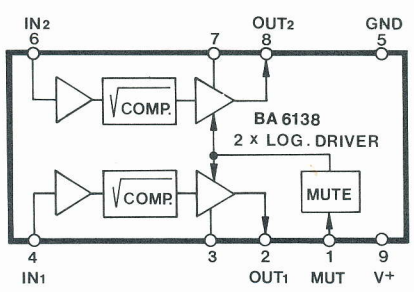
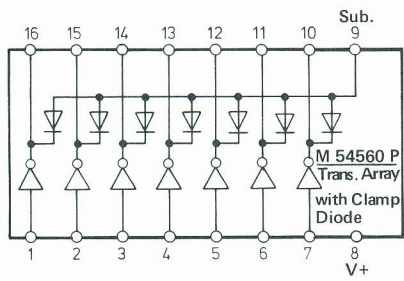

Grundplatte/Main Board L

- CN 301 → Lamp VU-Meter
- CN 302 → Erease, Head
- CN 303 → Record Head
- CN 304 → Play Head
- CN 305 → P 211 Connection Board
- CN 306 → P 212 Connection Board
- CN 307 → P 110 Peak Level Board
- CN 308 → CN 403 Dolby Board
- CN 309 → P 711 Selection Board
- P 310 → CN 601 Control Board
- P 311 → CN 601 Control Board
- P 312 → CN 391 Equalizer Board

L = Leiterseite/Wiring side/Côte de conducteur

Control

- CN 601 -
- CN 602 -
- CN 603 -
- CN 604 -
- CN 605 -
- CN 606 -
- CN 607 -

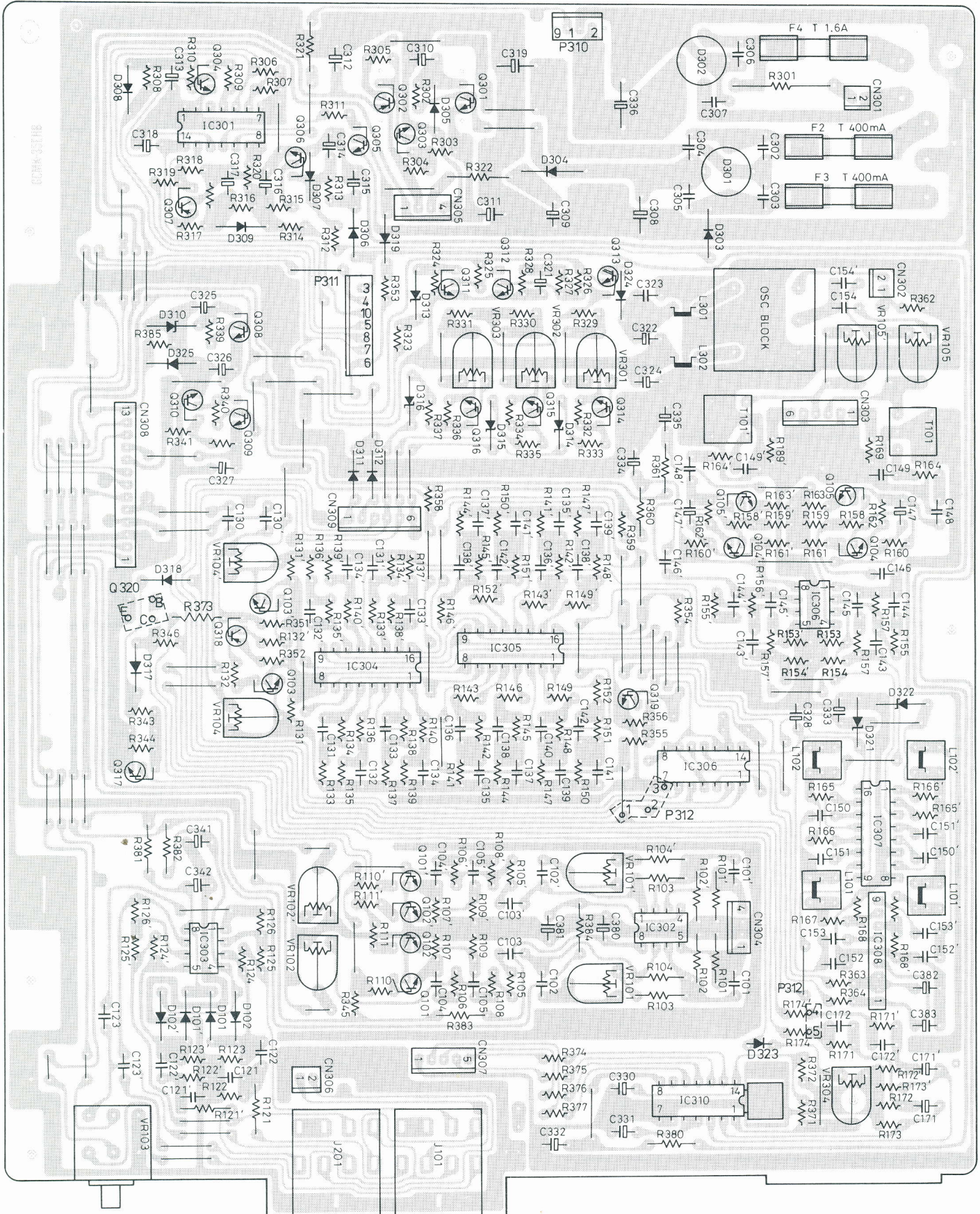

Controllplatte/Control Board L

- CN 601 → P 310, P 311 Main Board
- CN 602 → Counter Board
- CN 603 → DLL, Cassette Switch
- CN 604 → Memory Switch
- CN 605 → P 810 Touch Switch Board
- CN 606 → P 710 Selection Board
- CN 607 → Laufwerk

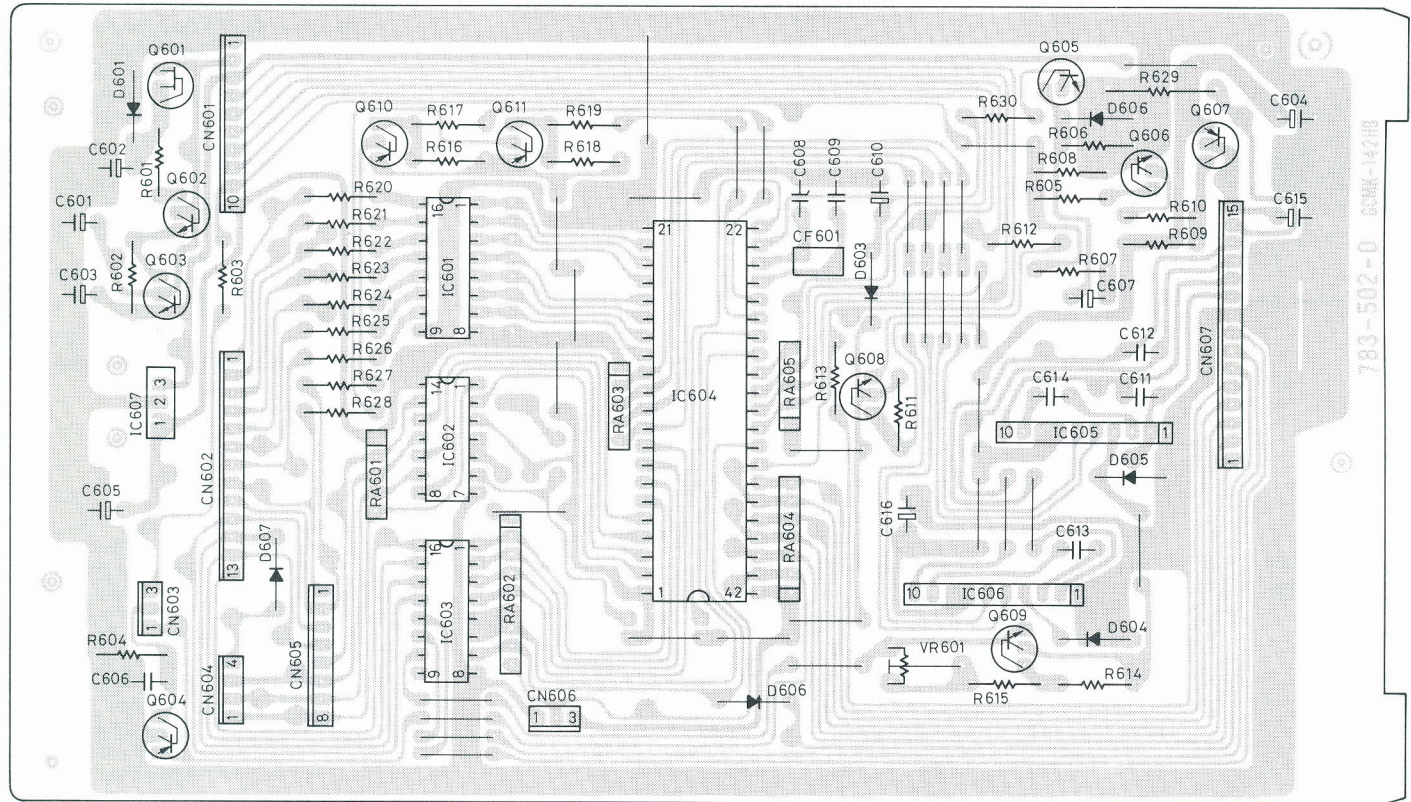

Selectionplatte/Selection Board L

- CN 701 → Capstan Motor
- CN 702 → Tape Selector (Laufwerk)
- CN 703 → Autotape Indicator
- P 710 → CN 606 Control Board
- P 711 → CN 309 Main Board
- P 712 → CN 401 Dolby Board

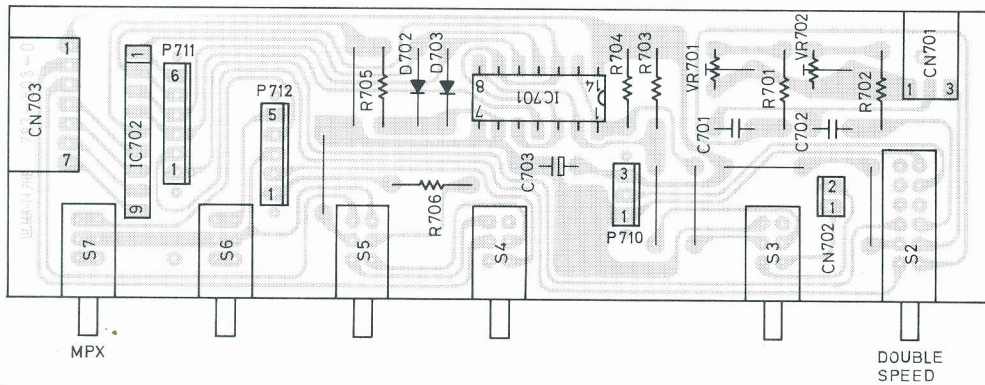

Tipptastenplatte/Touch Switch Board L

- P 810 → CN 605 Control Board

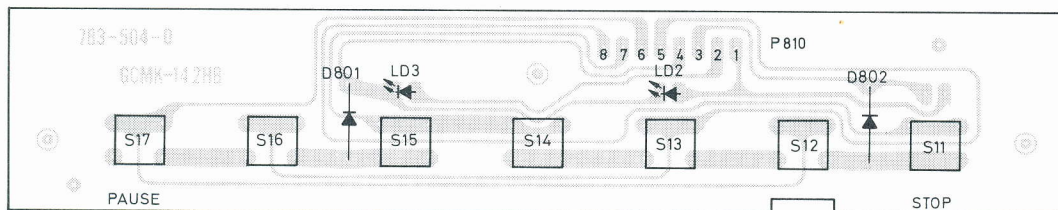

Dolbyplatte/Dolby Board L

CN 401 → P 712 Selection Board
 CN 402 → P 210 Connection Board
 CN 403 → CN 308 Main Board

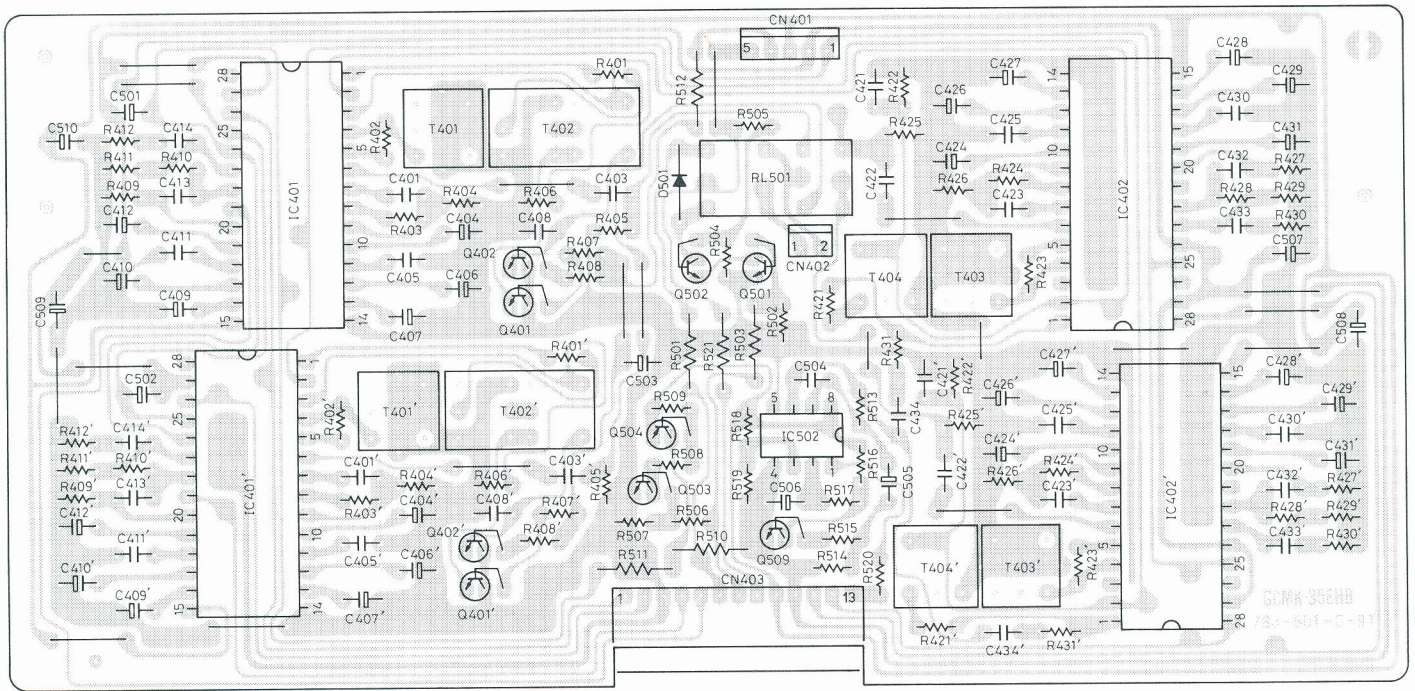

Entzerrerplatte/Equalizer Board L

CN 391 → P 312 Main Board

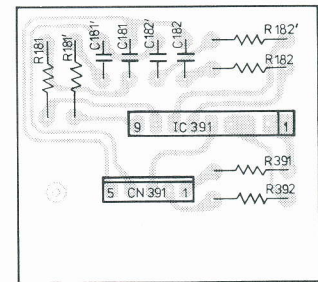

Anschlußplatte/Connection Board L

CN 309 → Headphone
 CN 310 → VU-Meter
 P 210 → CN 402 Dolby Board
 P 211 → CN 305 Main Board
 P 212 → CN 306 Main Board

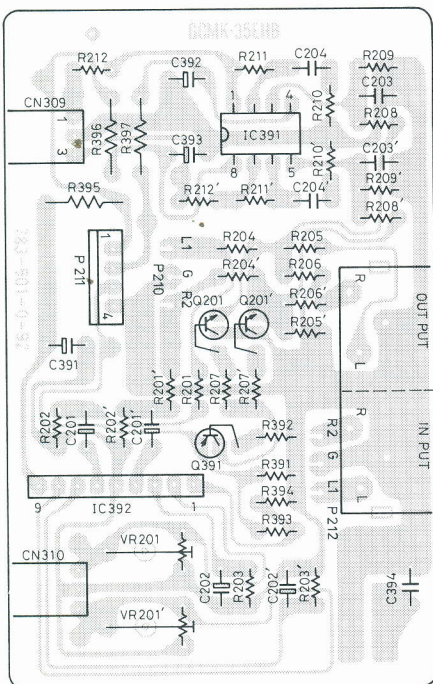

LED-Platte/LED board L

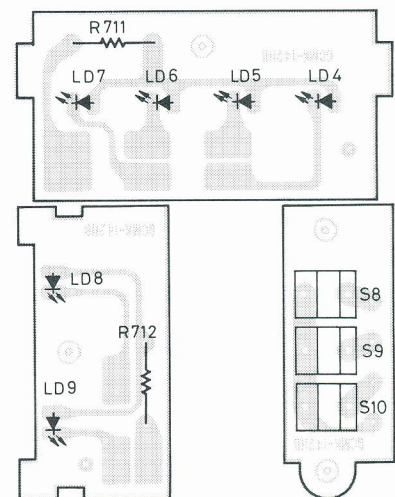

Prozessor TMP 4321 (IC 604) Pin Connection · Pinbelegung

Pin Signal

1 ←	⌋	+ 5 Volt		
2 ←	⌋			
3 ←	⌋	Record Switch	} 0000 Switch Memory Switch Set Switch	
4 ←	⌋	Pause Switch		
5 ←	⌋	Auto Space Switch		
6 →	⌋	Pulse Dekade 1		
7 →	⌋	Pulse Dekade 2	} Stop Switch Fast Forward Switch Rewind Switch Play Switch	
8 →	⌋	Pulse Dekade 3		
9 →	⌋	Pulse Dekade 4		
10 →	⌋	Slide Motor Forward ON		
11 →	⌋	Slide Motor Reverse ON		
12 →	⌋	Reel Motor Forward ON		
13 →	⌋	Reel Motor Reverse ON		
14 →	⌋	Pulse Segment a	} to Counter	
15 →	⌋	Pulse Segment b		
16 →	⌋	Pulse Segment c		
17 →	⌋	Pulse Segment d		
18 →	⌋	Pulse Segment e		
19 →	⌋	Pulse Segment f		
20 →	⌋	Pulse Segment g		
21		GND		
22		+ 5 Volt		
23 ←	⌋	Reset	Power ON	
24	}	Quartz		
25				
26 →	⌋	Pulse LED Record	} Dot Set Dek. 2	
27 →	⌋	Pulse LED Play		} Dot Memory Dek. 3
28 →	⌋	Right Reel Brake ON (rechte Bandwickelbremse)		
29 →	⌋	Capstan Motor ON, Reel Motor Tape Tension Level ON (Bandzug-Pegel)		
30 →	⌋	Pause, Muting, OFF	Record SB, Pause	
31 →	⌋	Record ON, Oscill. ON	Record SB, Record	
32 →	⌋	Record Amp Muting OFF	Record	
33 →	⌋	Line Muting OFF	Play, Record SB, Record	
34 ←	⌋	Double Speed (9.5 cm/s) ON	Double Speed	
35 ←	⌋	Signal Space (Musiklücke)	MF ►►, ◄◄	
36 ←	⌋	Tape Run Sensor	FF, RW, Play, MF ►►, ◄◄	
37 ←	⌋	Record Safety Switch	Musicassette	
38 ←	} see Logic Matrix	Slide Motor Position	} Position Tonkopfschlitten	
39 ←				
40 ←				
41 ←	⌋	DLL ON, Cassette Switch	Without a cassette, Kassette entfernt	
42		U _{BAT} + 5 Volt		

Remarks · Bemerkungen

FF, RW
Play, Record SB, Record, Auto Space, Pause
Play, Auto Space, FF, MF ►►
RW, MF ◄◄

Record SB, Record | Set
Play, Record SB | Memory
Play →, Record →, FF →, RW →, Stop
Play, Record, Record SB, Pause

Record SB, Pause
Record SB, Record
Record
Play, Record SB, Record
Double Speed
MF ►►, ◄◄
FF, RW, Play, MF ►►, ◄◄

Musicassette
} Position Tonkopfschlitten

Without a cassette, Kassette entfernt

Logic Matrix

Pin	38	39	40	in function
	L	L	H	Pause, Rec. SB, MF ►►, ◄◄ Tonkopfschlitten in Pos. Pause
	L	H	L	Play, Record, Auto Space Tonkopfschlitten in Pos. Play
	H	H	L	FF, RW
	H	L	L	Stop
				} Tonkopfschlitten in Pos. Stop

Signification · Bezeichnung:

2 ← Input
7 → Output
⌋ Signal HIGH active
⌋ Signal LOW active
Record SB = Record Stand By
FF = Fast Forward
RW = Rewind
MF = Music Finder
Slide Motor = Motor für Laufwerkfunktionen

Connector Main Board

CN 309	
Pin	Signal
1 ←	⌋ 9,5 cm/s
2 ←	⌋ 4,75 cm/s
3 ←	⌋ Met Tape
4 ←	⌋ Cr Tape
5 ←	⌋ Fe Tape
6 ←	⌋ FeCr Tape

P 311

Pin	Signal
3 ←	+ 12 V
4 →	⌋ Signal Space (Musiklücke)
10 ←	+ 5 V
5 ←	⌋ Line Mute OFF
8 ←	⌋ Pause
7 ←	⌋ Record ON
6 ←	⌋ Record Mute OFF

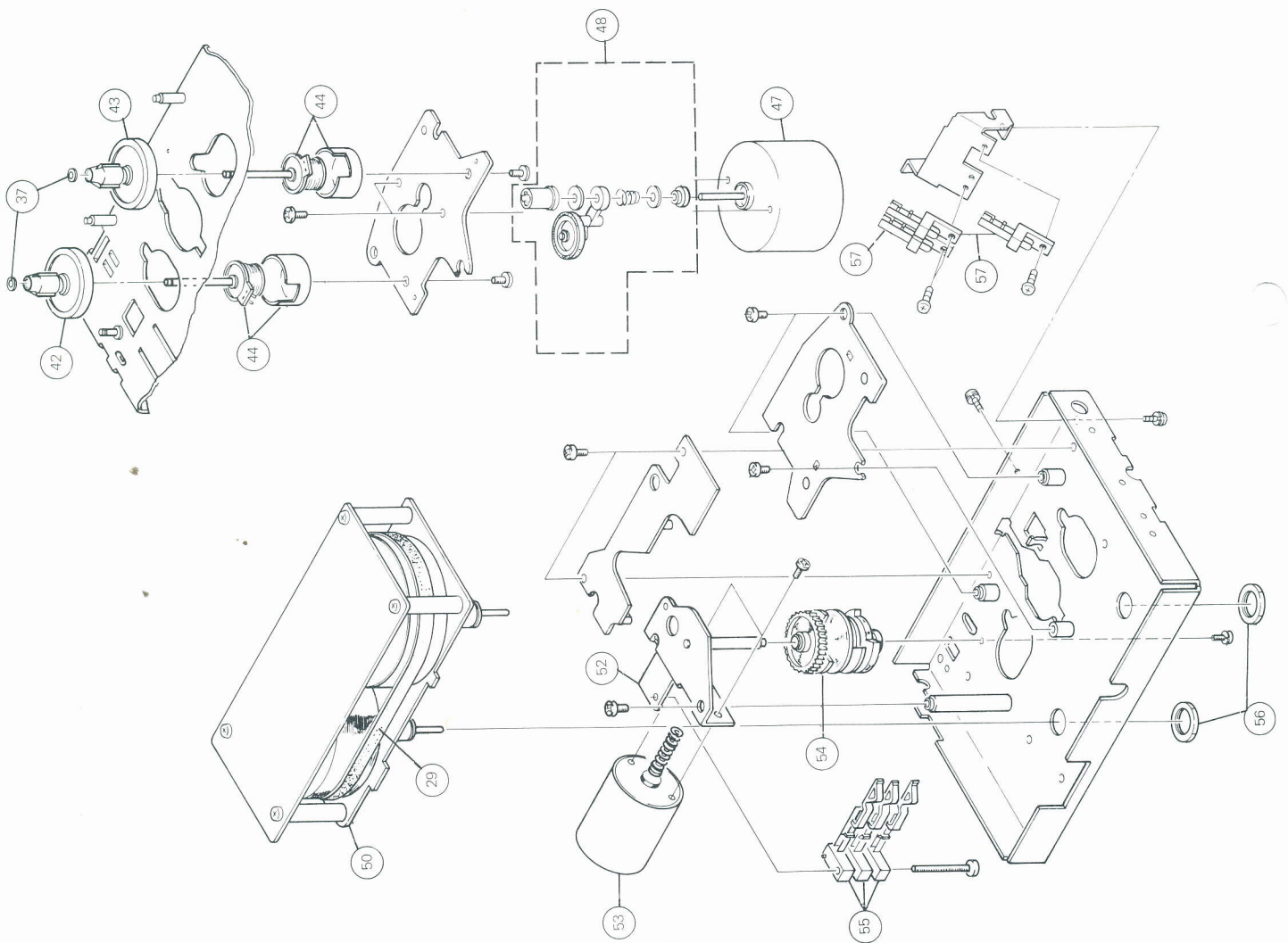
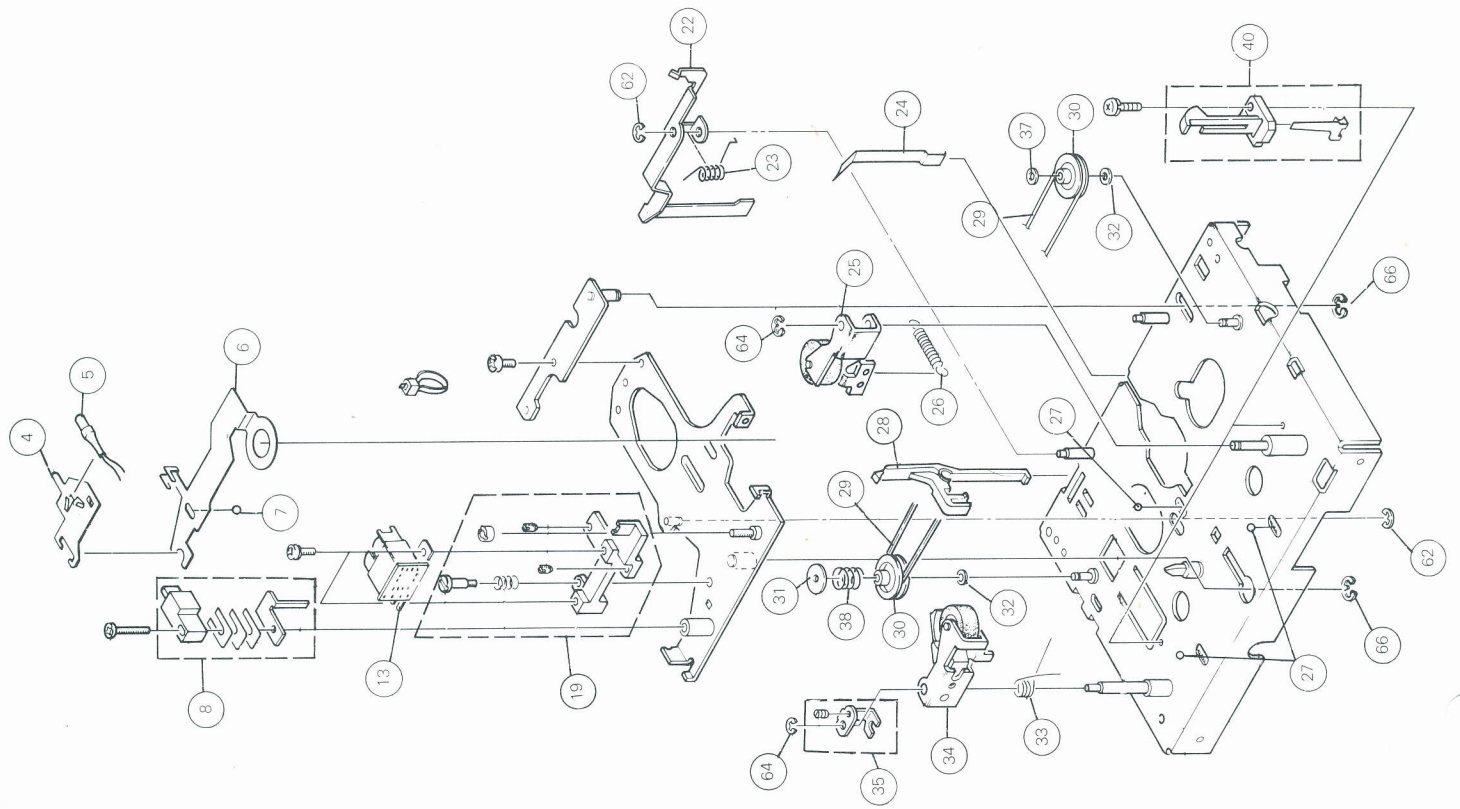

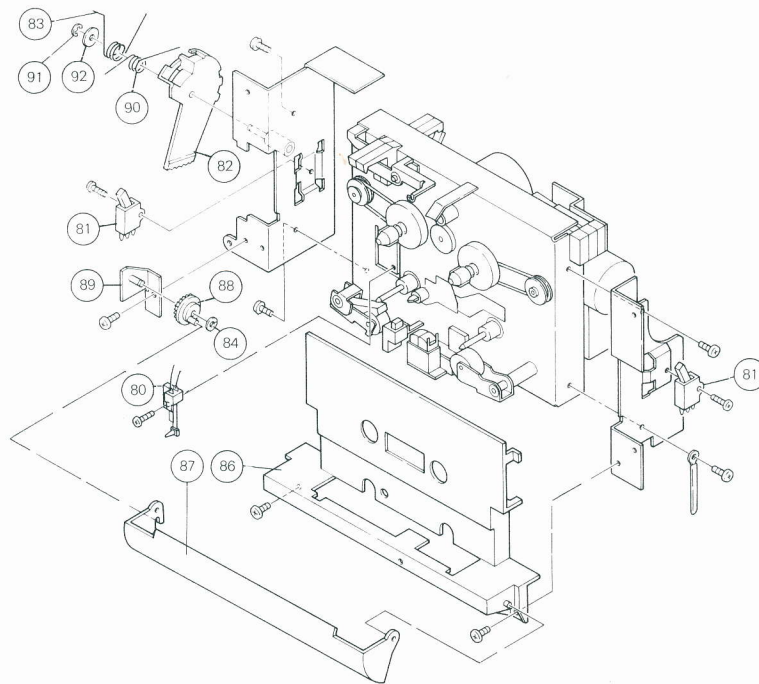

Ersatzteile · Replacement parts · Pièces détachées · C 846

Pos.	Art.-Nr.	Stck	Bezeichnung
4	278 456	1	Lampenhalter
5	278 457	1	Lampe
6	278 458	1	Stütze
7	278 459	1	Kugel
8	278 518	1	Löschkopf
13	278 519	1	AW-Kopf
19	278 520	1	Kopfräger kpl.
22	278 469	1	Schalthebel
23	278 470	1	Schenkelfeder
24	278 471	1	Cassettenhalter
25	278 472	1	Andruckhebel kpl. R
26	278 473	1	Zugfeder
27	209 353	3	Kugel 2,0
28	278 474	2	Recordhebel
29	278 665	1	Riemensatz
30	278 476	2	Rolle
31	278 477	1	Scheibe 1,8/8/0,5
32	278 478	2	Scheibe 2,1/4/0,5
33	278 479	1	Schenkelfeder
34	278 480	1	Andruckhebel kpl. L
35	278 521	1	Justageplatte kpl.
37	278 483	3	Scheibe 1,8/3,2/0,5
38	278 484	1	Druckfeder
40	278 522	2	Cassettenhalter
42	278 487	1	Mitnehmer L
43	278 488	1	Mitnehmer R
44	278 523	2	Mitnehmerachse kpl.
47	278 188	1	Motor (Reel)
48	278 524	1	Antriebsrolle kpl.
50	278 187	1	Motor (Capstan)
52	278 498	1	Getriebe support
53	278 189	1	Motor (Getriebe)
54	278 499	1	Getriebe
55	278 500	3	Schalter
56	278 501	2	Mutter M9
57	278 502	3	Schalter
62	278 503	2	Sicherungsscheibe 2,5
64	278 504	2	Sicherungsscheibe 2,0
66	278 505	2	Sicherungsscheibe 3,0
80	278 234	1	Schalter
81	278 071	2	Schalter
82	270 170	1	Dämpfungshebel
83	271 053	1	Schenkelfeder
84	278 235	1	Stopper
86	278 236	1	Abdeckung SM
86	278 580	1	Abdeckung AM
87	278 237	1	Kopfschutz
88	278 238	1	Dämpfungsrad
89	278 239	1	Getriebe lager
90	268 263	1	Spiralfeder B
91	278 503	2	Sicherungsscheibe 2,5
92	269 484	1	Scheibe 3,7/9/0,5

Pos.	Art.-Nr.	Stck	Bezeichnung
100	278 179	1	Grundplatte
D 101	264 086	15	Diode MA 150
D 102	264 086	15	Diode MA 150
D 301	265 534	1	Diode WO 2
D 302	272 681	1	Diode 2 W 02
D 303	264 086	15	Diode MA 150
D 304	272 334	1	Diode SR 1 K 2 LF
D 305	278 507	1	Diode HZ 12 C 1
D 306	264 086	15	Diode MA 150
D 307	245 343	1	Diode DA 90
D 308	264 086	15	Diode MA 150
D 309	264 086	15	Diode MA 150
D 310	278 210	1	Diode HZ 9 C 1 L
D 311	264 086	15	Diode MA 150
D 312	264 086	15	Diode MA 150
D 313	270 137	4	Diode HZ 15-1
bis			
D 316	270 137	4	Diode HZ 15-1
D 317	264 086	15	Diode MA 150
D 318	264 086	15	Diode MA 150
D 319	264 086	15	Diode MA 150
D 321	268 327	2	Diode HZ 6 B 3
D 322	268 327	2	Diode HZ 6 B 3
D 323	264 086	15	Diode MA 150
D 324	264 086	15	Diode MA 150
D 325	245 343	2	Diode OA 90
F 2	237 146	1	Sicherung T 0,4 A
F 3	237 146	1	Sicherung T 0,4 A
F 4	237 710	1	Sicherung T 1,6 A
J 101	272 949	2	Buchse (MIC)
L 101	278 196	1	Spule
L 102	278 196	4	Spule
L 301	273 777	2	Spule 1 mH
L 302	273 777	2	Spule 1 mH
Q 101	273 779	12	Transistor 2 SC 1685 S
Q 102	273 779	12	Transistor 2 SC 1685 S
Q 103	274 774	1	Transistor 2 SD 1302 T
Q 104	273 779	12	Transistor 2 SC 1685 S
Q 105	273 779	12	Transistor 2 SC 1685 S
Q 301	278 195	2	Transistor 2 SD 1406 GR
Q 302	278 193	2	Transistor 2 SB 1015 GR
Q 303	265 578	3	Transistor 2 SA 564
Q 304	273 779	12	Transistor 2 SC 1685 S
Q 305	273 779	12	Transistor 2 SC 1685 S
Q 306	278 217	2	Transistor 2 SC 3112 B
Q 307	265 578	3	Transistor 2 SA 564
Q 308	278 195	2	Transistor 2 SD 1406 GR
Q 309	278 193	2	Transistor 2 SB 1015 GR
Q 310	265 578	3	Transistor 2 SA 564
Q 311	278 217	2	Transistor 2 SC 3112 B
Q 312	273 779	12	Transistor 2 SC 1685 S

Pos.	Art.-Nr.	Stck	Bezeichnung	
Q 313	278206	1	Transistor 2 SD 1198 R	
Q 314	273779	12	Transistor 2 SC 1685 S	
	bis			
Q 317	273779	12	Transistor 2 SC 1685 S	
Q 318	265578	4	Transistor 2 SA 564	
Q 319	273779	12	Transistor 2 SC 1685 S	
Q 320	278794	1	Transistor UN 4211	
R 261	278508	2	Sicherungswiderstand 150 Ω	
R 360	278508	2	Sicherungswiderstand 150 Ω	
R 361	278508	2	Sicherungswiderstand 150 Ω	
T 101	278197	1	Spule	
IC 301	263172	1	IC MC 14081	
IC 302	278207	2	IC AN 6558	
IC 303	260189	1	IC TBB 1458 B	
IC 304	278209	3	IC TC 4052 BP	
IC 305	278209	3	IC TC 4052 BP	
IC 306	273836	1	IC 4071 BP	
IC 307	278209	3	IC TC 4052 BP	
IC 308	278208	1	IC TD 62554 S	
IC 309	278207	1	IC AN 6558	
IC 310	271144	1	IC LB 1436	
OC 1	278202	1	Spule	
VR 101	278199	1	Steller 1 kΩ	
VR 102	263041	3	Steller 20 kΩ	
VR 103	278198	1	Steller 10 kΩ	
VR 104	263041	3	Steller 20 kΩ	
VR 105	278201	1	Steller 47 kΩ	
VR 301	278200	2	Steller 2 kΩ	
VR 302	278200	2	Steller 2 kΩ	
VR 303	270193	1	Steller 5 kΩ	
VR 304	263041	3	Steller 20 kΩ	
	110	278497	1	Dolby-Platte kpl.
D 501	264086	1	Diode MA 150	
Q 401	273779	3	Transistor 2 SC 1685 S	
Q 402	273779	3	Transistor 2 SC 1685 S	
Q 501	278217	2	Transistor 2 SC 3112 B	
Q 502	273779	3	Transistor 2 SC 1685 S	
Q 503	278217	1	Transistor 2 SC 3112 B	
Q 504	265578	1	Transistor 2 SA 564	
Q 509	273779	4	Transistor 2 SC 1685 S	
T 401	273776	2	Spule	
T 402	278216	1	Filter	
T 403	273776	2	Spule	
T 404	278214	1	Spule	
IC 401	278218	2	IC TEA 0665	
IC 402	278218	2	IC TEA 0665	
IC 501	260189	1	IC TBB 1458 B	
RL 501	278215	1	Relais	
	115	278506	1	Anschlußplatte
	116	278327	1	Anschlußbuchsen
Q 201	274774	1	Transistor 2 SD 1302 T	
Q 391	265578	1	Transistor 2 SA 564	
R 395	278508	3	Sicherungswiderstand 150 Ω	
R 396	278508	2	Sicherungswiderstand 150 Ω	
R 397	278508	3	Sicherungswiderstand 150 Ω	
IC 391	278219	1	IC NJM 4556	
IC 392	278220	1	IC BA 6138	
VR 201	263222	1	Steller 500 Ω	
	120	278181	1	Controlplatte
D 601	278507	1	Diode HZ 12 C 1	
D 602	264086	3	Diode MA 150	
D 603	264086	3	Diode MA 150	
D 604	278227	1	Diode HZ 9 C 1	
D 605	278509	1	Diode HZ 7 B 1	
D 606	278228	1	Diode HZ 3 B 2	
D 607	264086	3	Diode MA 150	
Q 601	273904	1	Transistor 2 SK 246 Y	
Q 602	278223	1	Transistor 2 SC 1685 Q	
Q 603	278195	1	Transistor 2 SD 1406 GR	
Q 604	265578	1	Transistor 2 SA 564	
Q 605	278217	1	Transistor 2 SC 3112 B	
Q 606	278217	1	Transistor 2 SC 3112 B	
Q 607	278193	1	Transistor 2 SB 1015 GR	
Q 608	273779	2	Transistor 2 SC 1685 S	
Q 609	273779	2	Transistor 2 SC 1685 S	
Q 610	265578	1	Transistor 2 SA 564	
Q 611	265578	2	Transistor 2 SA 564	
CF 601	271101	1	Keramik-Filter	
IC 601	270225	1	IC M 54560 P	
IC 602	270180	1	IC TC 4069 UBP	
IC 603	271105	1	IC TD 62104 P	
IC 604	278221	1	IC UP TMP 4321	

Pos.	Art.-Nr.	Stck	Bezeichnung	
IC 605	273973	1	IC BA 6109	
IC 606	278226	1	IC BA 6209	
IC 607	278225	1	IC AN 7805	
RA 601	278510	2	Netzwerk 10 K	
RA 602	278511	1	Netzwerk 4,7 K	
RA 603	278510	2	Netzwerk 10 K	
RA 604	278512	1	Netzwerk 2,2 K	
RA 605	278513	1	Netzwerk 4,7 K	
VR 601	278200	1	Steller 2 kΩ	
	125	278182	1	Selectionsplatte
D 701	264086	1	Diode MA 150	
D 702	264086	1	Diode MA 150	
S 2-7	278232	1	Druckastenset	
IC 701	273840	1	IC TC 4001 BP	
IC 702	278208	1	IC TD 62554 S	
VR 701	278231	2	Steller 50 kΩ	
VR 702	278231	2	Steller 50 kΩ	
	130	278184	1	Frontteil SM kpl.
	130	278781	1	Frontteil AM kpl.
	131	278243	1	Frontblende SM
	131	278793	1	Frontblende AM
	132	278244	1	Knopf SM
	132	278789	1	Knopf AM
	133	278515	1	Tipptastenplatte
	134	274053	1	Taste SM kpl.
	134	278594	1	Taste AM kpl.
	136	274056	1	Taste SM
	136	278792	1	Taste AM kpl.
	137	278516	1	LED-Platte
	138	278242	1	Anzeigeelement
D 801	264086	2	Diode DD 150	
D 802	264086	2	Diode DD 150	
S 8	270221	3	Tipptaster	
S 9	270221	3	Tipptaster	
S 10	270221	3	Tipptaster	
S 11	274447	7	Tipptaster	
	bis			
S 17	274447	7	Tipptaster	
LD 1	278245	1	LED SL 1012	
LD 2	273786	5	LED GL 9 NG 24	
LD 3	274417	1	LED GL 9 PR 24	
LD 4	273786	5	LED GL 9 NG 24	
	bis			
LD 7	273786	5	LED GL 9 NG 24	
LD 8	278086	2	LED GL 9 HY 24	
LD 9	278086	2	LED GL 9 HY 24	
	128	278783	1	Entzerrerplatte LED
IC 391	278208	1	IC TD 62554 S	
	140	278079	1	Drehknopf R SM
	140	278786	1	Drehknopf R AM
	141	272326	1	Drehknopf L SM
	141	278785	1	Drehknopf L AM
	145	278185	1	Cassetten-Abdeckung SM
	145	278782	1	Cassetten-Abdeckung AM
	147	278332	1	Taste SM kpl.
	147	278795	1	Taste AM kpl.
	150	278186	1	Rückwand kpl.
	150	278248	1	Rückwand
	151	278247	1	Netztrafo
	152	277989	1	Netzschalter
	153	243750	1	Netzkabel Europa
	155	278192	1	Taste SM
	155	278784	1	Taste AM
	156	278517	1	Tastenverlängerung
	157	268311	1	Gelenkfeder
	160	266528	1	Kopfhörerbuchse
	162	268315	4	Fuß
	164	274717	1	Stromversorgungsplatte
	165	272671	1	Gehäuseblech SM
	165	275896	1	Gehäuseblech AM
	166	272673	4	Schraube 4 x 6
	166	275907	4	Schraube 4 x 6 AM
	167	221269	1	Sicherung T 0,16 A
	277966	1	Bedienungsanleitung C 846	
	278274	1	Verpackungskarton SM	
	278791	1	Verpackungskarton AM	
	278275	1	Seitenteil L	
	278276	1	Seitenteil R	
	278277	1	Seitenteil F	

Änderungen vorbehalten! / Subject to change! / Sous réserve de modification!