

TECHNISCHER KUNDENDIENST

Service-Information



Stereo Clipper 3040 986.100 H

Technical data · Caractéristiques principales · Technische Daten Características del aparato · Dati tecnici

Type of set : Stereo cassette player Type d'appareil : Lecteur de cassettes stéréophonique Geräteart : Stereokassetten-Wiedergabegerät Tipo de aparato : Lector de cassettes estereofonico Tipo d'apparecchio : Lettore di cassettes stereofonico	
Tape speed : Vitesse de défilement : Bandgeschwindigkeit : 4,75 cm/s Velocidad de la cinta : ± 3 % Velocità del nastro :	Wow and flutter : Fluctuations : 0,25 % Gleichlauf : Fluctuaciones : Fluttuazioni :
Frequency response : Courbe de réponse : 63 Hz - 10 KHz Frequenzgang : Curva de respuesta : Curva di risposta :	Signal to noise ratio : Rapport signal/bruit : 48 dB Geräuschspannungsabstand : Relación señal/ruido : Rapporto segnale/disturbo :
Total harmonic distortion : Distortion harmonique : Klirrfaktor : 1,5 % Distorsión armónica : Distorsione armonica :	Stereo separation: Diaphonie: Übersprechdämpfung: 30 dB Diafonia: Diafonia:
Power supply : Alimentation : Stromversorgung : 3 V --- 2 \times IEC R6 Alimentación : Alimentazione :	2 \times 20 mW Zs = 32 Ω

NORDMENDE

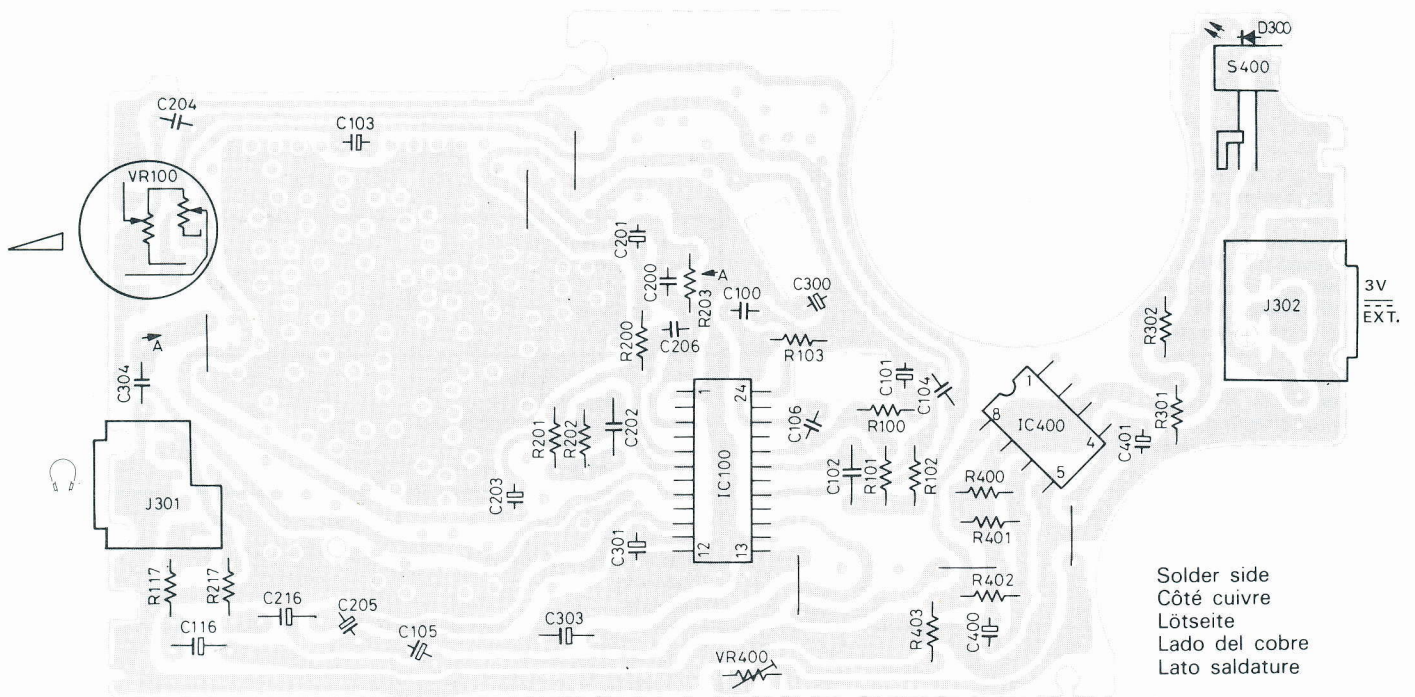
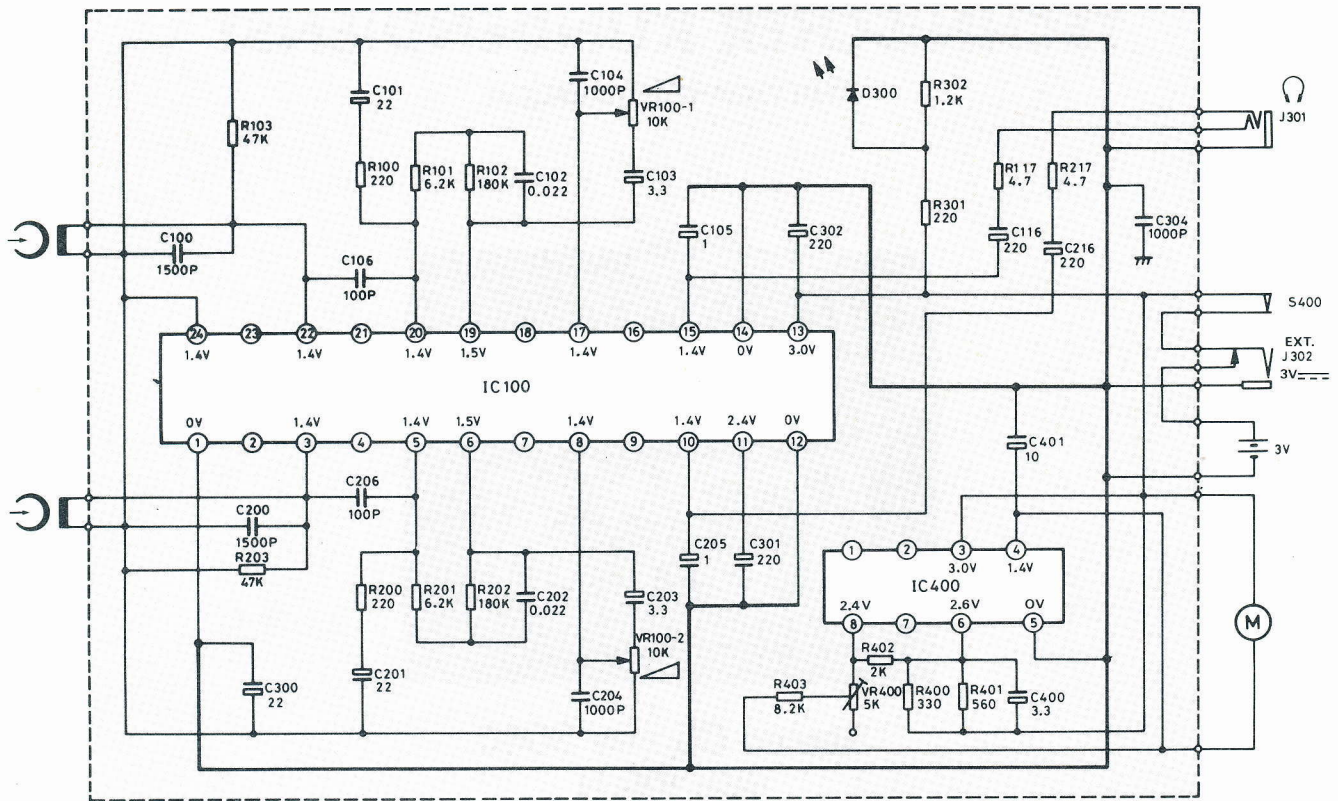

Solder side
 Côté cuivre
 Lötseite
 Lado del cobre
 Lato saldature

NORDMENDE

**Stereo Clipper 3040
 986.100 H**

IC 100	IC 400	D 300
BA 3 505 F	NJM 2 606 D	TLR 102 A

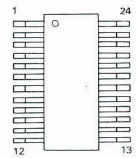

BA 3505 F

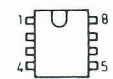

NJM 2606 D